

The Domino A200+

The industry standard high performance ink jet coder



Main Features:

High Reliability

- Large volume reservoir based ink system ensures stable performance in any application
- Patented sealed nozzle print head and true autoflush ensure reliable start-ups, even after extended periods of shut down
- Sealed cartridge fluid replenishment.

Connectivity and Flexibility

- Built in Ethernet port enabling printers to be networked
- Built in web server to allow remote message selection and status monitoring
- Ability to set printer-generated email/SMS alerts
- All rasters and print formats on board allowing the machine to be configured from the user interface or via a networked PC
- External USB port for location based set ups, moving messages between printers and service diagnostics
- Print up to four lines with a variety of print formats
- Optional colour touch screen control.



Making More Time for your Business:

- Full control of networked factory printers from the comfort of your desk
- Simplified one-touch on/off button powers up the jet ready to start printing and when pressed to shut down, automatically flushes the head and powers off to ensure the machine is always available
- Prepare/edit messages while the printer is still running to reduce code/product changeover times
- Set up wizards improve accuracy, speed-up installation and allow printer tasks to be optimised for maximum effectiveness.



Optional touch screen control



Ethernet and USB ports as standard

Technical Specification:

A200+

Control Unit

Control Panel:	Membrane touch button or optional 10.4" SVGA colour touch screen
Cabinet:	Stainless Steel (304) designed to IP53 (BSEN 60529:1992)
Cabinet dimensions:	245mm x 475mm x 725mm (9.6" x 18.7" x 28.5")
Weight:	36kg (79lbs)
Character Control	Auto repeat, Character width and height adjustment, Auto invert/reverse, User defined clock format, Print delay, Sequential/batch numbering, Product counter, Inverse reverse and bold characters, Message repeat.

Ink System

Viscosity control:	Automatic
Ink bleed control:	Automatic on start up
Ink and make-up refill:	825ml (.87qt) cartridge automatically metered
Peltier:	Optional

Print head

Dimensions:	240mm x 41mm x 47mm (9.45" x 1.61" x 1.85")
Conduit length:	3m (11'8) or 6m (23'6)
Positive air:	Optional internal supply
Airdryer:	Internal compressor or factory air option

Environment

Temperature range:	5 – 45°C (40 – 112°F) operating
Humidity:	10 – 90% (non-condensing)
Electrical requirements:	Single phase, fully auto-ranging 100-250V, 47-63Hz

Standard Connections

Product detector:	npn/pnp12V 100mA for photocell or proximity detector. IP68 6-way socket
Shaft encoder input:	npn/pnp encoder 12V via IP68 6-way socket
Alarm beacon connector:	IP68 7-way socket
Auxiliary alarms connector:	IP68 9-way plug
Ethernet:	IP68 RJ45 Connector
USB1.1:	IP68 USB connector

Options

User port connector:	IP68 25-way socket
Data Input/Output Options:	Serial RS232, Rate: 110-38.4k Baud, software configurable,

Accessories

Full range of photocells, stands and bracketry

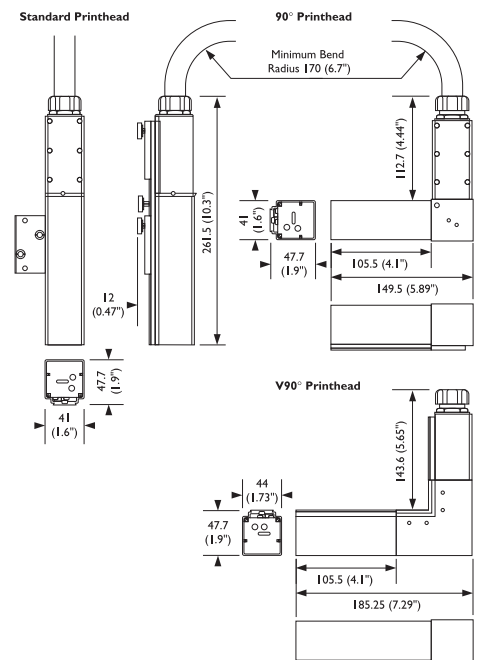
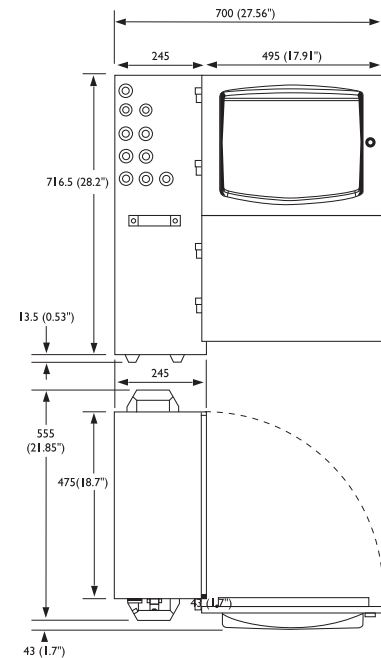

Australia
Domino (Australia) Pty. Ltd.
Unit 12
6 Gladstone Road
Castle Hill
Sydney
NSW 2154
Tel: + 61 2 9894 7833

Canada
Domino Printing
Solutions Inc.
2751 Coventry Road
Oakville
Ontario
L6H 5V9
Tel: + 1 800 387 7972

India
Domino Printech India
Private Limited
167, Udyog Vihar Phase I,
H.S.I.D.C Gurgaon -
122016 Haryana
Tel: + 91 124 500 7406

United Arab Emirates
Domino UK Ltd (Dubai)
PO Box 16984
Jebel Ali
Dubai
Tel: + 971 4 88 35003

United Kingdom
Domino UK Ltd
Bar Hill
Cambridge
CB23 8TU
Tel: + 44 1954 782 551

United States of America
Domino Amjet, Inc.
1290 Lakeside Drive
Gurnee
Illinois 60031
Tel: + 1 800 486 7414



www.domino-printing.com

