

Brass Ball Valves

Two-Piece Body • Full Port • Blowout-Proof Stem • TFE Seats

1/4"-2" 600 PSI/41.4 Bar Non-Shock Cold Working Pressure

2 1/2"-4" 400 PSI/27.6 Bar Non-Shock Cold Working Pressure

CONFORMS TO MSS SP-110 • CSA TO ASME B 16.44 AND CR 91-002
• UL LISTED • NSF/ANSI 61-8

MATERIAL LIST

PART	SPECIFICATION
1. Body	Copper Alloy
2. End Cap	Copper Alloy
3. Ball Seat	PTFE
4. Ball	Copper Alloy, Chrome Plated
5. Stem	Copper Alloy
6. O-Ring (Stem Seal)*	Fluorocarbon (FKM)
7. Stem Packing	PTFE
8. Packing Nut	Copper Alloy
9. Lever Handle ¹	Steel, Plated
10. Lock Washer*	Stainless Steel
11. Handle Nut ¹	Stainless Steel

Note: *Parts 6 and 10 are applicable of S-FP-600A only.

¹ Due to Standard Approvals, Lever Handles and Nuts are not interchangeable between Solder and Threaded. There are no handle options at this time.

CSA and UL approvals for T-FP-600A 1/2" - 2" only.



T-FP-600A
Threaded



S-FP-600A
Solder

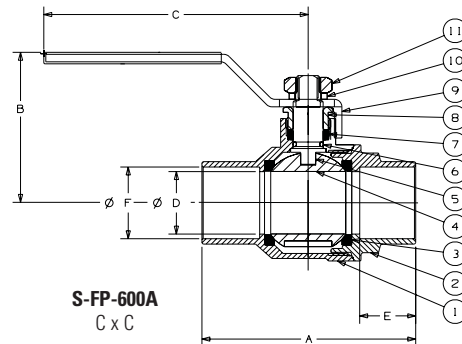
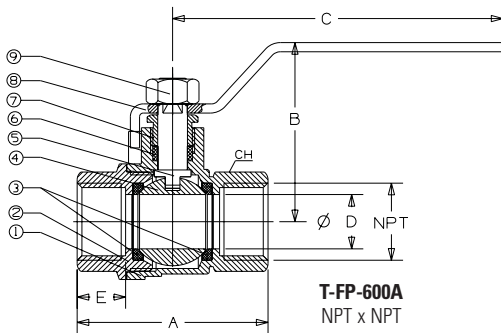

DIMENSIONS—WEIGHTS—QUANTITIES

Dimensions

Size	T-FP-600A		S-FP-600A		T-FP-600A		S-FP-600A		T-FP-600A		S-FP-600A		Port D		T-FP-600A		S-FP-600A		T-FP-600A		S-FP-600A	
	In.	mm.	In.	mm.	In.	mm.	In.	mm.	In.	mm.	In.	mm.	In.	mm.	Lbs.	Kg.	Lbs.	Kg.	Ctn.	Qty.	Ctn.	Qty.
1/4	8	1.76	45	—	—	1.73	44	—	—	3.54	90	—	—	.39	10	.33	.15	—	—	18	—	—
3/8	10	1.76	45	1.75	44	1.73	44	1.58	40	3.54	90	3.78	96	.39	10	.30	.14	.38	.17	18	18	18
1/2	15	2.05	52	2.01	51	1.92	49	1.78	45	3.54	90	3.78	96	.59	15	.44	.20	.38	.17	18	18	18
3/4	20	2.36	60	2.74	70	2.09	53	2.13	54	3.78	96	3.98	101	.75	19	.66	.30	.64	.29	12	12	12
1	25	2.76	70	3.35	85	2.56	65	2.52	64	4.53	115	4.41	112	.98	25	1.10	.50	.99	.45	6	6	6
1 1/4	32	3.31	84	3.78	96	2.95	75	2.65	67	4.53	115	5.04	128	1.26	32	1.57	.71	1.40	.63	4	4	4
1 1/2	40	3.66	93	4.42	112	3.35	85	3.12	79	5.51	140	6.22	158	1.57	40	2.40	1.09	2.17	.98	2	2	2
2	50	4.18	106	5.34	136	3.68	93	3.41	87	5.51	140	6.22	158	1.97	50	3.37	1.53	2.97	1.35	2	2	2
2 1/2	65	5.38	137	6.28	160	4.76	121	4.76	121	8.66	220	8.66	220	2.56	65	7.60	3.45	6.36	2.88	3	3	3
3	75	6.04	153	7.15	182	5.08	129	5.08	129	8.66	220	8.66	220	2.95	75	9.36	4.24	8.32	3.77	2	2	2
4	100	7.39	188	—	—	5.87	149	—	—	9.61	244	—	—	3.89	99	16.85	7.64	—	—	1	—	—

*S-FP-600A 3/8" - 2" (S1), 2 1/2" - 3" (S2)

*T-FP-600A 1/4" - 4" (S2)

