

Class 125/250 Iron Body Silent Check Valves

Wafer Style • Renewable Seat and Disc • Spring Actuated (1/2 PSI Cracking Pressure)

Class 125, 200 PSI/13.8 Bar Non-Shock Cold Working Pressure
Class 250, 400 PSI/27.6 Bar Non-Shock Cold Working Pressure
Maximum Temperature to 200° F/93° C

CONFORMS TO MSS SP-125 • FM APPROVED
W910-B — 2" thru 10" ONLY

MATERIAL LIST

PART	SPECIFICATION
1. Body	Cast Iron ASTM 126 Class B
2. Seat	Bronze ASTM B 584 Alloy C83600 (B)
2a. Seat	Buna-N Bonded to Bronze (W)
3. Disc	Bronze ASTM B 584 Alloy C83600
4. Spring	Stainless Steel Type 316 ASTM A 313
5. Bushing	ASTM B 16
6. Set Screws	Stainless Steel Type 304 ASTM F 879



W-910 125 lb. Class
W-960 250 lb. Class

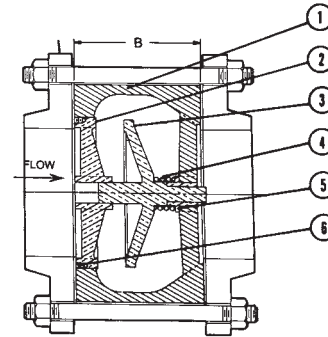

W-910-B/W-960-B
Wafer

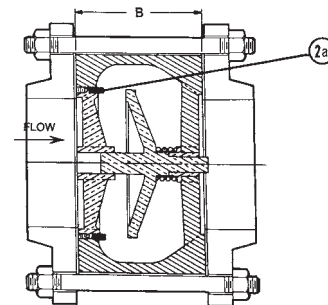

W-910-W/W-960-W
Wafer

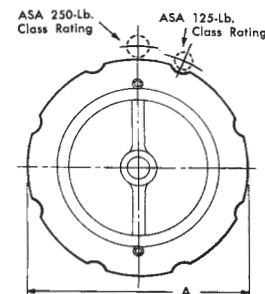

W-910-B/W-960-B
Wafer

DIMENSIONS—WEIGHTS—QUANTITIES

Size	Dimensions				W-910		W-960		
	In.	mm.	In.	mm.	In.	mm.	Lbs.	Kg.	
*2	50	4.25	108	2.63	67	6	5	6	3
*2½	65	5.00	127	2.88	73	7	3	7	3
*3	80	5.75	146	3.13	79	12	5	12	5
*4	100	7.00	178	4.00	102	18	8	18	8
*5	125	8.38	213	4.63	117	27	12	27	12
*6	150	9.75	248	5.50	140	42	19	42	19
8	200	13.38	340	6.50	165	†85	39	86	39
10	250	16.00	406	8.25	210	†146	66	†137	62

* NOTE: Sizes 2" thru 6" have dual class ratings (125 lb. and 250 lb.) resulting in W-910 and W-960 being identical. 8" and 10" have special machining in accordance with Flange Class.

316 Stainless Steel Trim available – Consult Factory.
316 Stainless Steel Trim w/FKM Seat available – Consult Factory

† Class 125 only.
‡ Class 250 only.

USE THIS VALVE ONLY WITH FLAT FACE FLANGE AND FULL FACE GASKET

WARNING: 1. Seat end of valve must be mated to a standard flat faced metal flange. Rubber flanges not acceptable.

2. These are not to be used as steam valves.
3. Valves are not to be used near a reciprocating air compressor.
4. Install 5 pipe diameters minimum downstream from pump discharge or elbows to avoid flow turbulence. Flow straighteners may be required in extreme cases.

Note: On pump discharge, the preferred check valves are:

- inline, spring assisted, center-guided, lift checks
- spring assisted twin (double) disc
- swing design with lever and weight or lever and spring

You should also install the check valve as far from the pump as possible and at a minimum length of 5 times the pipe diameter. Flow straighteners may be required.

◆ For detailed Operating Pressure, refer to Pressure Temperature Chart on page 113.