

Kelvion



Goedhart® air coolers

Goedhart® Blast freezers (PLK.s)

FREEZE!!







**Kelvion –
a tribute to
Lord Kelvin**

**70 branches and
sales partners
worldwide**

**More than 4,000
employees
worldwide**

Lord Kelvin (1824 – 1907) formulated
the laws of thermodynamics

EXPERTS IN HEAT EXCHANGE - SINCE 1920

Welcome to Kelvion. As successor to the GEA Heat Exchangers Group, we continue to break new ground, making discerning customers more successful than ever with our integrated heat exchanger solutions.

Our solutions for your applications:

We offer our customers one of the world's largest product portfolios in the field of heat exchangers. It includes individual solutions for practically all conceivable applications and complex environmental conditions: plate heat exchangers, shell and tube heat exchangers, finned tube heat exchangers, modular cooling tower systems, and refrigeration heat exchangers.

Your markets are our markets, too:

The markets in which you and we together operate are among the most important in the world: energy, the oil and gas industry, the chemical industry, marine applications, food and beverages, climate and environment. We provide every single market segment with solutions of outstanding efficiency, safety, and sustainability.

We are highly committed to earning your trust:

We want to win your trust with everything we do and convince you with the solutions we offer. With this high aim in mind, we invest our extensive know-how, our great precision, and our passion in everything we do: including product development, manufacturing, installation, and after-sales support.

Seeing things from the customer perspective:

Your specific requirements count – and nothing else. Whatever we offer you, it must meet these requirements. Our entire way of thinking and working is geared towards this aim. Our customers truly appreciate this: after all, this is how we make their companies more efficient.

We are at your service.

Kelvion – Experts in Heat Exchange.

THE VISIBLE AND INVISIBLE QUALITY

The food industry is an important market for us. Almost all freezing and cooling supplying companies in the freezing tunnel- and spiral world use our equipment. For every kind of application We design together with the client, in a discrete manner, an OEM solution that suits their demands. Varying from compact to mega IQF freezers, Carton Freezers, spiral freezers, Multi belt tunnels and special inline freezer/chillers, we provide an exact fitting solution.

Our coils can be found in the above mentioned solutions for example in tunnels or spirals for French Fries, pizza, bread, pastry, chicken, ice cream, meat, snacks, vegetables processing, etc.

In the area of Carbon Footprint reduction we are also leading, in developing our equipment for environmentally-friendly refrigerants like CO₂, ammonia (NH₃) and secondary refrigerants like Mono Propylene Glycol .

1 Coil, The heart of a Heat Exchanger

Robust and reliable, excellent performance through a combination of quality materials, craft manship and experienced engineering.

Coil configuration and materials:

Goedhart® PLK air coolers are available with all the Goedhart tube configurations and materials:

- Copper tubes / Aluminium fins
- Stainless steel tubes / Aluminium fins
- Stainless steel tubes / Stainless steel fins
- Steel hot dipped galvanized tubes and fins
- On request Aluminium tubes and fins

2 Construction, durable and clever

Different casing materials are used for a robust construction.

The following casing materials are available:

- galvanized sheet steel
- galvanized sheet steel with a white finishing
- stainless steel
- aluminium

The space between the coil block and the leg keep cold brigging to a minium.

Legs to fix the air cooler on the floor or to the ceiling.

3 Drip tray

An extra wide drip tray to collect all condensation water from the side end plates of the coil.

The aluminium inner tray provided with special profiles for optimal conductivity for a hotgas coil or electrical heating elements.

Options for the drip tray are insulation in the galvanized steel outer tray to prevent condensation at the outside of the drip tray of a hygienic polyester drip tray to prevent condensation and is easy to clean.

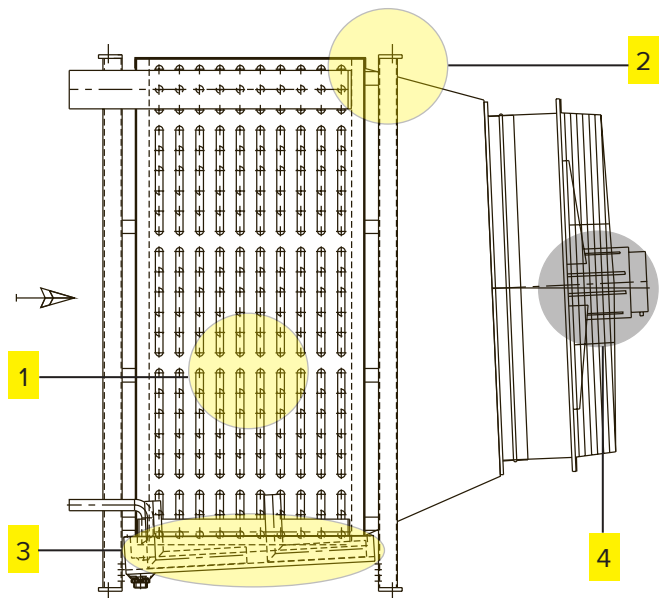

4 Fans

Different suppliers of fans give you a wide choice of fan options
Axiale flow fans are angled up, which means:
condensed water will flow back in de drip tray of the air cooler
less danger of freezing of the impeller
longer air throw for draw-through air coolers

Optional fan heating elements prevent freezing of the impeller in low temperature applications

Applications

The Goedhart® PLK.s air coolers are used in a wide range of industrial applications:

- Blast freezers
- Freezing tunnels
- Holding rooms
- Cold stores
- Processing areas

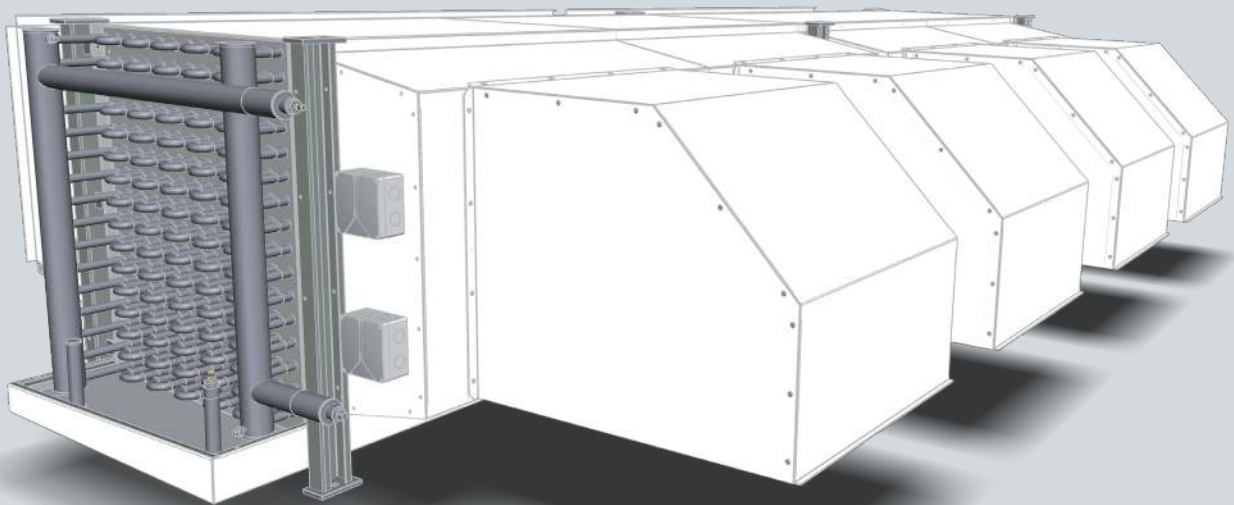
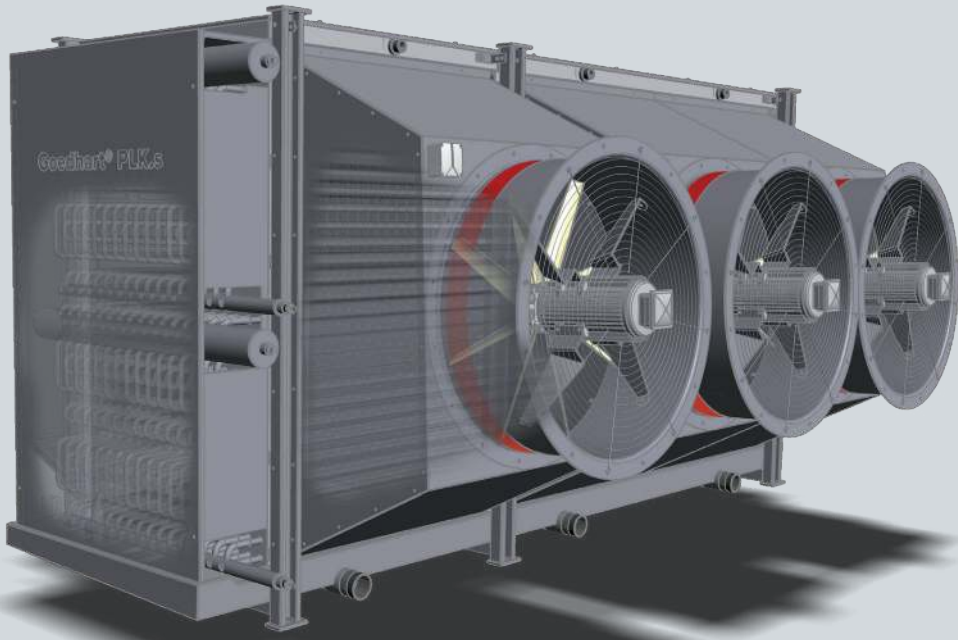

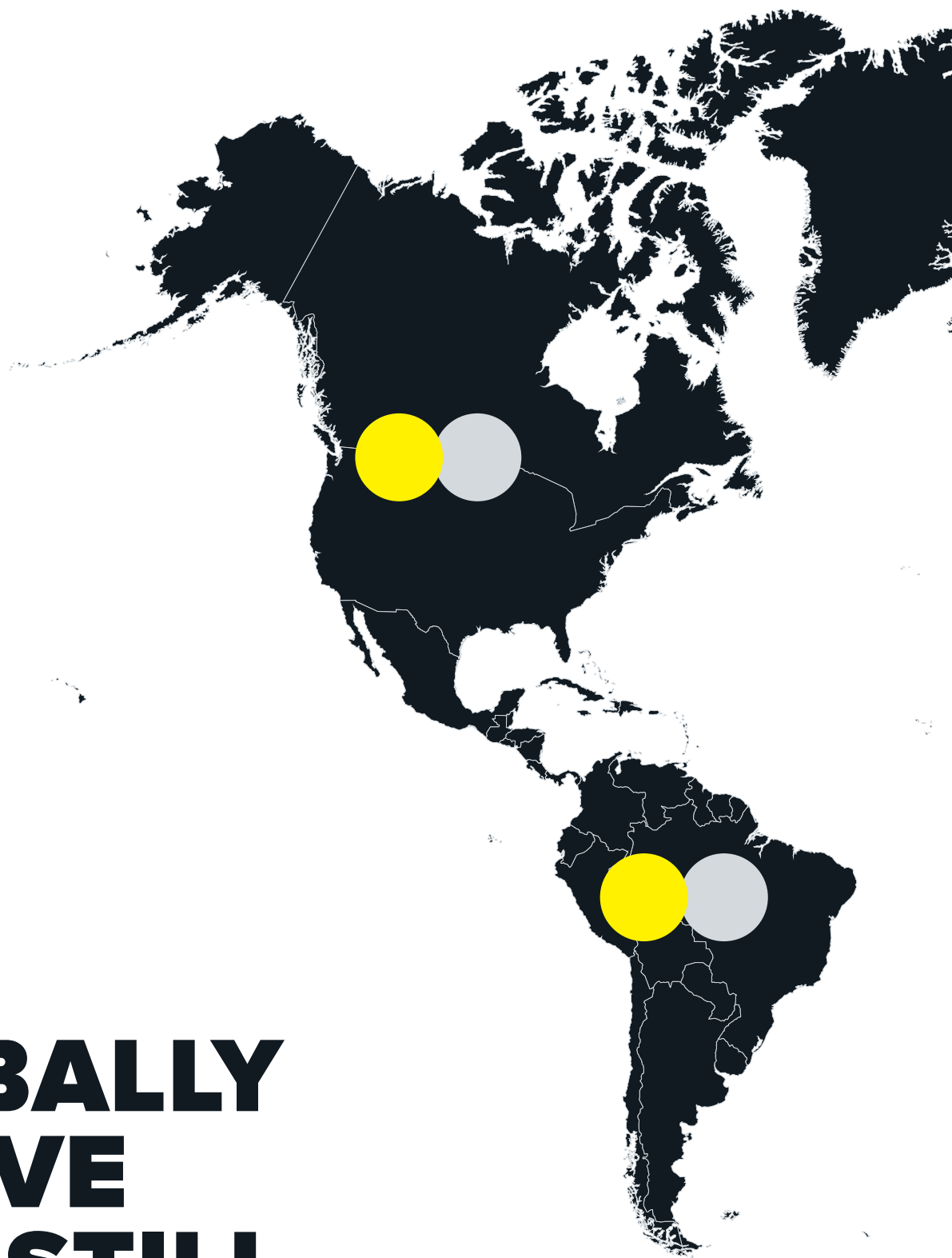

GLOBALLY ACTIVE AND STILL CLOSE BY

No matter where your market is, regardless of country, we are never far away. We are always happy to answer any questions you may have and meet your requirements. Even the largest, most successful project begins with an initial, profitable conversation. We look forward to hearing from you.

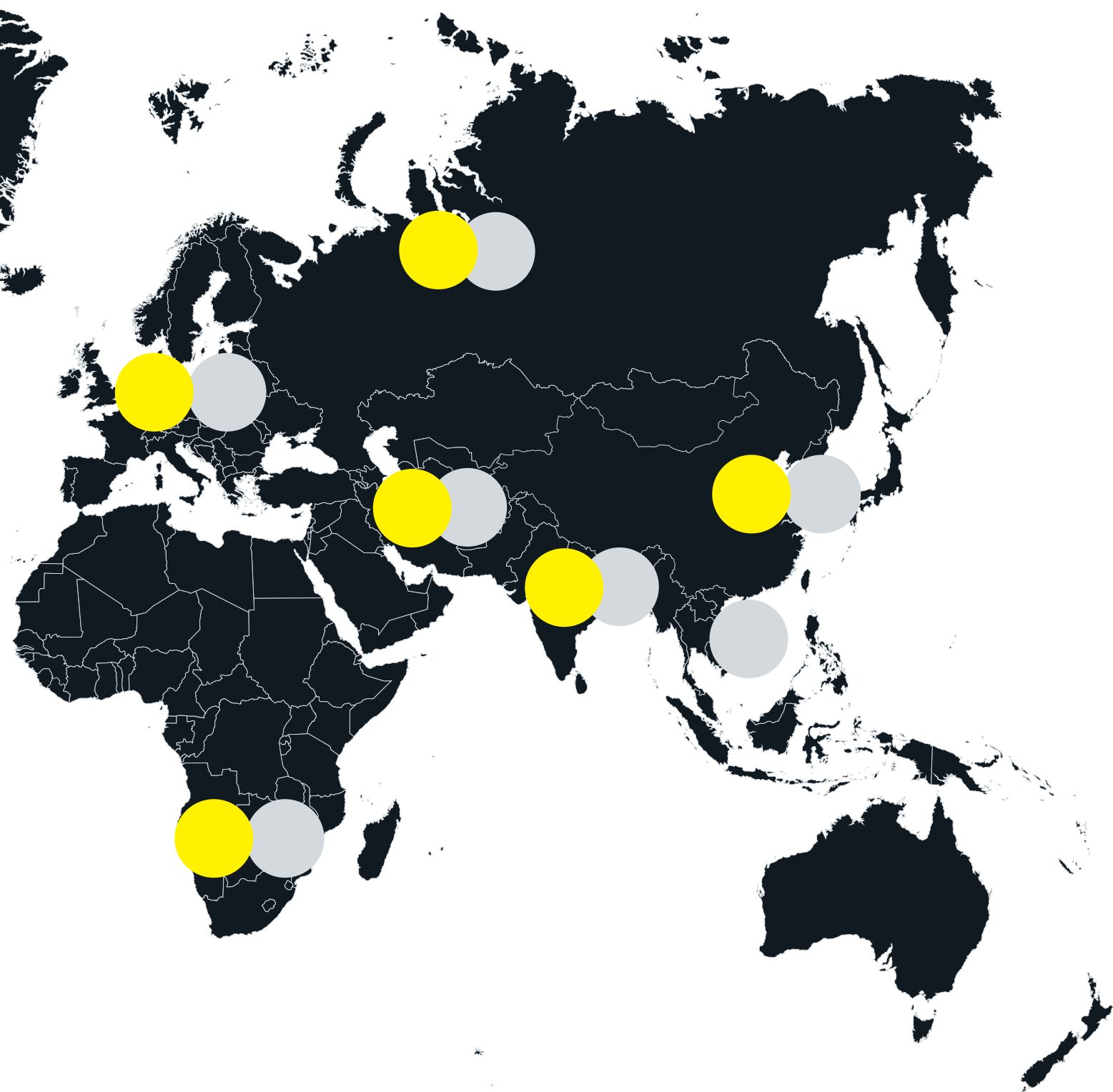

● Global production footprint

● Global sales and service



Just scan this QR code with your smartphone or visit our website at: www.kelvion.com – there you will find a highly competent contact in your immediate vicinity.

www.kelvion.com