

ebm-papst Mulfingen GmbH & Co. KG

Bachmühle 2 · D-74673 Mulfingen

Phone +49 7938 81-0

Fax +49 7938 81-110

info1@de.ebmpapst.com

www.ebmpapst.com

Limited partnership · Headquarters Mulfingen

County court Stuttgart · HRA 590344

General partner Elektrobau Mulfingen GmbH · Headquarters Mulfingen

County court Stuttgart · HRB 590142

Nominal data

Type	S3G300-AK13-50	
Motor	M3G055-CF	
Phase		1~
Nominal voltage	VAC	230
Nominal voltage range	VAC	200 .. 240
Frequency	Hz	50/60
Type of data definition		ml
State		prelim.
Speed	min ⁻¹	1500
Power input	W	85
Current draw	A	0.74
Max. back pressure	Pa	85
Min. ambient temperature	°C	-25
Max. ambient temperature	°C	+60

ml = max. load · me = max. efficiency · fa = running at free air · cs = customer specs · cu = customer unit
Subject to alterations



Technical features

Size	300 mm
Surface of rotor	Passivated
Material of terminal box	ABS plastic, black
Material of electronics housing	Die-cast aluminium
Material of impeller	PP-GF40 plastic
Material of guard grille	Steel, phosphated and coated in black plastic
Number of blades	5
Direction of air flow	"V"
Direction of rotation	Counter-clockwise, seen on rotor
Type of protection	IP 54
Insulation class	"B"
Max. permissible ambient motor temp. (transp./ storage)	+ 80 °C
Min. permissible ambient motor temp. (transp./storage)	- 40 °C
Mounting position	Any
Condensate discharge holes	None, open rotor
Operation mode	S1
Motor bearing	Ball bearing
Technical features	- Soft start - Over-temperature protected electronics / motor
Speed steps	2
EMC interference immunity	Acc. to EN 61000-6-2 (industrial environment)
EMC harmonics	Acc. to EN 61000-3-2/3
EMC interference emission	Acc. to EN 61000-6-3 (household environment)
Touch current acc. IEC 60990 (measuring network Fig. 4, TN system)	<= 3.5 mA
Electrical leads	Via terminal box
Motor protection	Locked-rotor protection
Cable exit	Variable
Protection class	I (if protective earth is connected by customer)
Product conforming to standard	EN 60335-1; CE

EC axial fan - HyBlade®

sickled blades (S series)

with guard grille for short nozzle

Product drawing

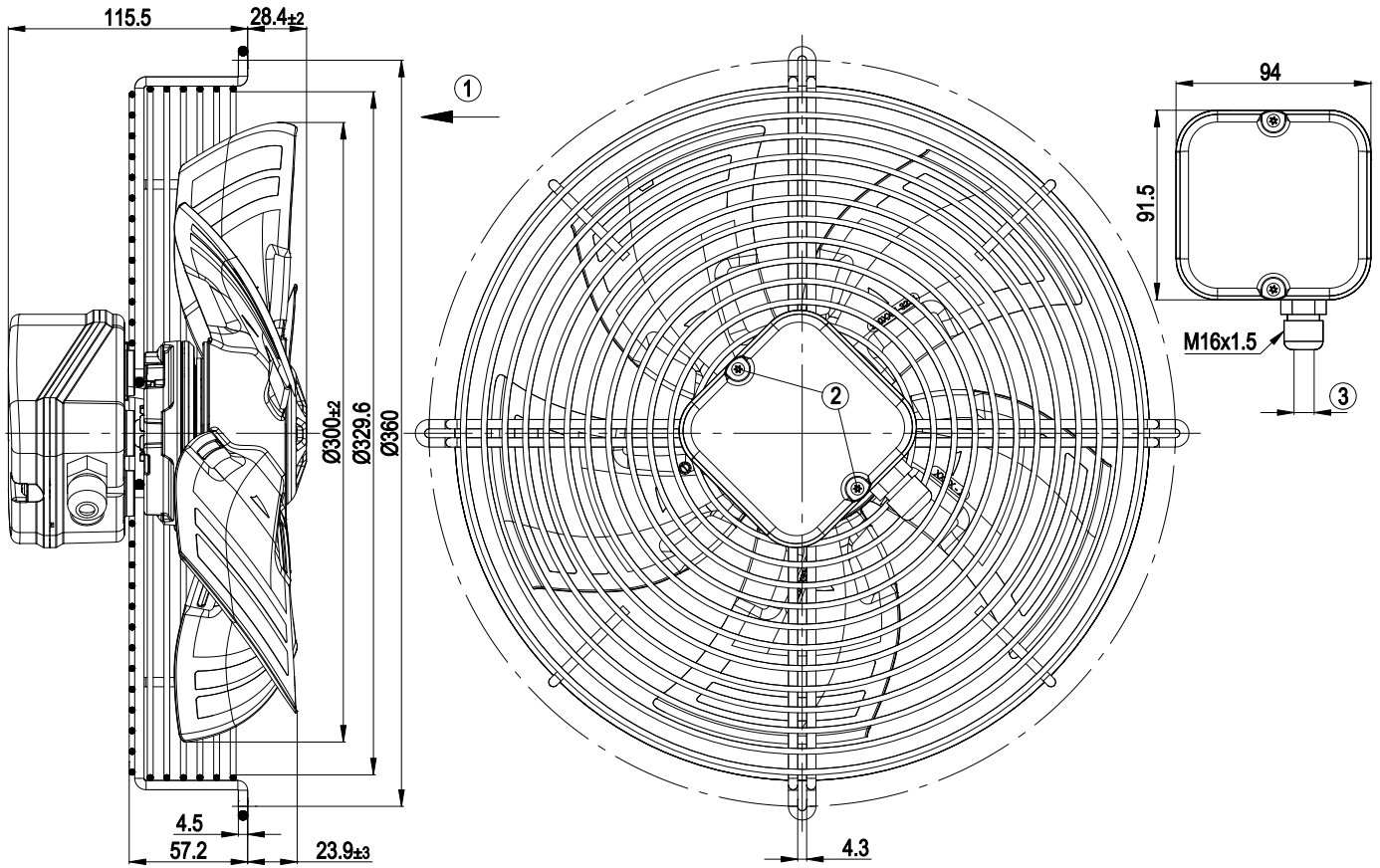

1	Direction of air flow "V"
2	Tightening torque 0.8±0.15 Nm
3	Cable diameter: max. 7.5 mm; tightening torque 2±0.3 Nm



EC axial fan - HyBlade®

sickled blades (S series)
with guard grille for short nozzle

Connection screen

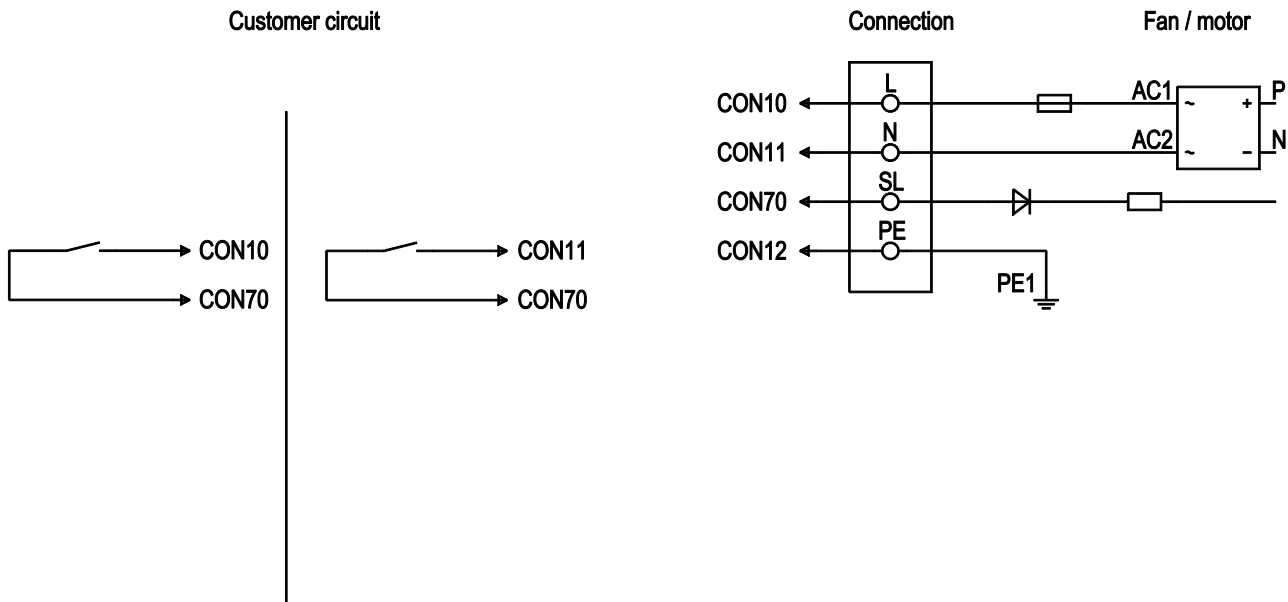

Line	No.	Signal	Colour	Function / assignment
	CON 10	L	black	Power supply 230 VAC, 50 - 60 Hz, see type plate for voltage range
	CON 11	N	blue	Neutral conductor
	CON 12	PE	green/yellow	Protective earth
	CON 70	SL	brown	Speed selection: switch open = speed 1; switch closed = speed 2



Charts: Air flow 50 Hz

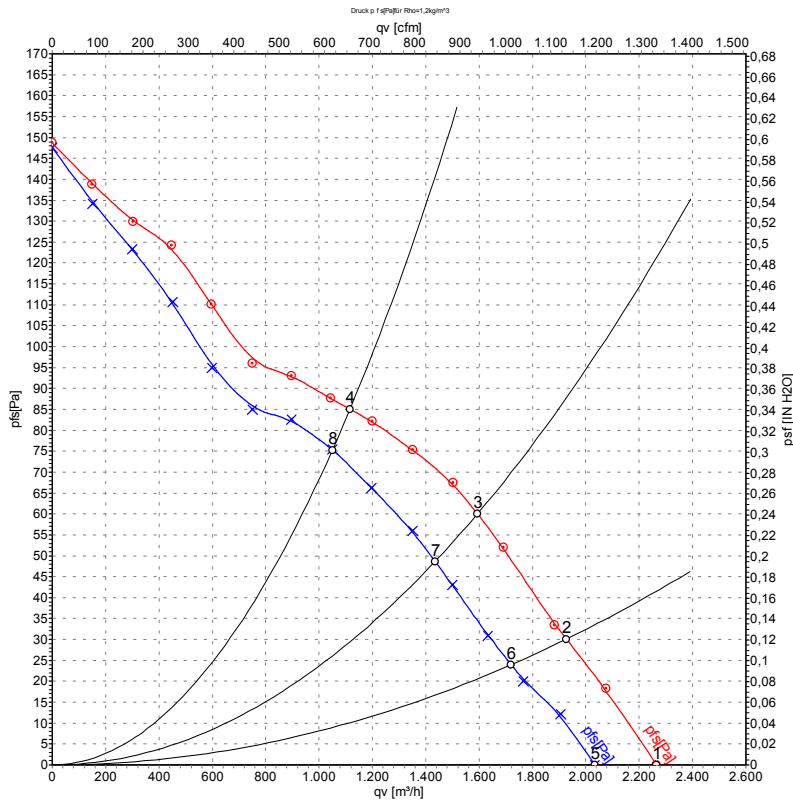

Measurement: LU-133717
Measurement: LU-133719

Air performance measured as per ISO 5801 Installation category A. For detailed information on the measuring set-up, please contact ebm-papst. Suction-side noise levels: LwA measured as per ISO 13347 / LpA measured with 1m distance to fan axis. The values given are valid under the measuring conditions mentioned above and may vary according to the actual installation situation. With any deviation from the standard set-up, the specific values have to be checked and reviewed with the unit installed.

Measured values

	U	f	n	P _{ed}	I	LpA _{in}	LwA _{in}	qv	p _{fs}
	V	Hz	min ⁻¹	W	A	dB(A)	dB(A)	m ³ /h	Pa
1	230	50	1650	72	0.63	55	63	2265	0
2	230	50	1595	78	0.67	56	63	1925	30
3	230	50	1565	83	0.70	55	62	1595	60
4	230	50	1500	85	0.74	56	64	1115	85
5	230	50	1485	52	0.48	53	60	2035	0
6	230	50	1440	57	0.52	53	60	1720	24
7	230	50	1405	60	0.53	52	60	1435	49
8	230	50	1365	65	0.59	54	62	1050	76

U = Supply voltage · f = Frequency · n = Speed · P_{ed} = Power input · I = Current draw · LpA_{in} = Sound pressure level inlet side · LwA_{in} = Sound power level inlet side · qv = Air flow
p_{fs} = Pressure increase

