

300/350 PSI WWP Iron Body Gate Valves

Fire Protection Valve • Bolted Bonnet • Outside Screw and Yoke • Solid Wedge • Class 250 Flanges

300/350 PSI/20.7/24 Bar Non-Shock Cold Water

CONFORMS TO MSS SP-70 • UL LISTED 350 PSI • FM APPROVED 300 PSI
• APPROVED BY NEW YORK CITY M.E.A. 420-92-E VOL. 2 AT 350 PSI NON-SHOCK COLD WATER

MATERIAL LIST

PART	SPECIFICATION
1. Stem	Brass ASTM B16 Alloy C36000
2. Handwheel Nut	Cast Bronze ASTM B584 Alloy C84400
3. Identification Plate	Aluminum
4. Yoke Bushing	Cast Bronze ASTM B584 Alloy C84400
5. Handwheel	Cast Iron ASTM A126 Class B
6. Bonnet Cap Nut	Steel ASTM A307
¹ 7. Bonnet Cap	Ductile Iron ASTM A536
¹ 8. Bonnet	Cast Iron ASTM A126 Class B
9. Bonnet Cap Bolt	Steel ASTM A307
10. Gland Follower Nut	Brass ASTM B36
11. Gland Follower	Ductile Iron ASTM A536
12. Packing Gland	Zinc Plated Powdered Iron ASTM B310 or Brass ASTM B16
13. Packing	Non Asbestos
14. Gland Follower Bolt	Steel ASTM A307
15. Backseat Bushing	Cast Bronze ASTM B584 Alloy C84400
16. Body Nut	Steel ASTM A307
17. Body Gasket	Non Asbestos
18. Body Bolt	Steel ASTM A307
19. Body	Cast Iron ASTM A126 Class B
20. Stem Collar	Cast Bronze ASTM B584 Alloy C84400
² 21. Wedge	Cast Iron ASTM A126 Class B
³ 22. Wedge Nut	Cast Bronze ASTM B584 Alloy C84400
23. Wedge Pin	Silicon Bronze B140 Alloy C31600
24. Seat Ring	Cast Bronze ASTM B584 Alloy C84400
² 25. Wedge Face Ring	Cast Bronze ASTM B584 Alloy C84400

- ¹ Sizes 2½" thru 6" made as shown using bonnet cap.
8" thru 10" made with separate yoke bolted to bonnet.
- ² Wedge construction - 2½" thru 3" all bronze.
4" thru 10" cast iron with bronze wedge face rings.
- ³ Bronze wedge nuts used on sizes 6" thru 10".

DIMENSIONS—WEIGHTS—QUANTITIES

Size	Dimensions										Weight		
	A		B		C		D		E		Lbs.	Kg.	
In. mm.	In.	mm.	In.	mm.	In.	mm.	In.	mm.	In.	mm.			
2½	65	9.5	241	18.44	468	8.00	203	7.50	191	1.00	25	74	34
3	80	11.13	283	20.50	521	10.00	254	8.25	210	1.13	29	122	55
4	100	12.00	305	27.00	686	12.00	305	10.00	254	1.25	32	193	88
6	150	15.88	403	33.00	838	16.00	406	12.50	318	1.44	37	411	186
8	200	16.50	419	45.50	1156	16.00	406	15.00	381	1.63	41	637	290
10	250	18.00	457	56.00	1422	20.00	508	17.50	445	1.88	48	897	408



F-697-0
Flanged

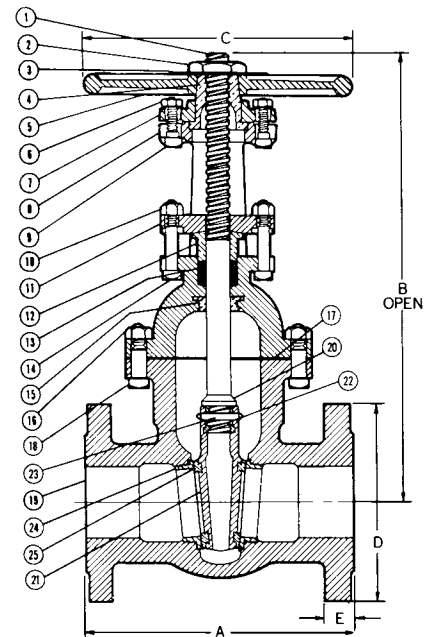

F-697-0
Flg x Flg



FREEZING WEATHER PRECAUTION: Subsequent to testing a piping system, gate valves should be left in an open position to allow complete drainage.