

Bronze Gate Valve PN20 Rising Stem • Screw in Bonnet

Thread Ends comply to BS21 Taper Thread (ISO 7)

Conforming to BS 5154 or BSEN 12288

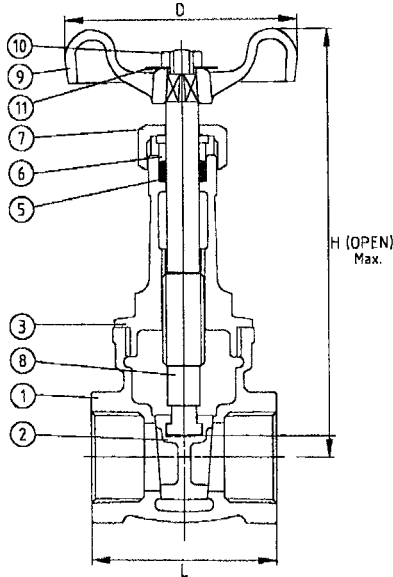

NP 408

MATERIAL LIST

PART	MATERIAL	SPECIFICATION (BS)
1. Body	Cast Bronze	1982 CC490K
2. Disc	Cast Bronze	1982 CC490K
3. Bonnet	Cast Bronze	1982 CC490K
5. Stem Packing	Teflon	PTFE
6. Gland	Brass	12164 CW603N
7. Packing Nut	Brass	12164 CW603N
8. Stem	Brass	12164 CW603N
9. Handwheel	Cast Iron	1561 EN-JL 1030
10. Wheel Nut	Steel	--
11. Name Plate	Aluminum	--

Pressure Testing

Shell 30 Bar
Seat 22 Bar

Pressure Rating

9 bar at 180°C
20 bar from -10°C to 100°C

DIMENSIONS (mm)

Nominal Size Inch(mm)	D	H	L	Wt. (Kg)
1/2" (15mm)	53.0	117.0	47.0	0.33
3/4" (20mm)	64.0	140.0	51.0	0.56
1" (25mm)	70.0	167.0	58.6	0.72
1 1/4" (32mm)	80.0	195.0	63.0	1.00
1 1/2" (40mm)	90.0	222.0	67.0	1.38
2" (50mm)	102.0	264.0	73.5	1.94

Freezing weather precaution: Subsequent to testing a piping system, valves should be in an open position to allow complete drainage.