

Wye Type Vic-Strainer®

SERIES 732

Series 732 Vic-Strainer provides straight through flow for lower pressure drop. Installs with two Victaulic couplings. Series 732 strainers range in size from 2 – 12”/50 – 300mm. All sizes are rated to 300 psi/2065 kPa maximum working pressure.

A factory installed Blow Down Drain Valve is available upon request, however this option is only offered for limited sizes of the Series 732*. The blow-down valve has a hose connection capable of piping system water to a drain when servicing Air Handling Units.

Durable 304 stainless perforated metal basket, 0.062" diameter holes for 2 – 3”/50 – 80mm sizes; 0.125" diameter holes for 4 – 12”/100 – 300mm sizes standard.

For information on the AGS Series W732 Wye Type Vic-Strainer in 14-18”/300-400mm sizes, request publication 20.19.

*Available in sizes 2 ½”/65 mm, 3”/80mm, 4”/100 mm and 6”/150 mm.



*Available in limited sizes for Air Handling Units.



WARNING

WARNING

- Always depressurize and drain piping systems before attempting to install, remove, or adjust any Victaulic piping products.

Failure to follow this instruction could result in serious personal injury, property damage, joint leakage, and/or joint failure.

MATERIAL SPECIFICATIONS

Body, Coupling, End Cap: Ductile iron conforming to ASTM A-395, grade 65-45-15, and ASTM A-536, grade 65-45-12.

Coating: Orange enamel.

Basket: Stainless Steel, Type 304, perforated metal.

- 2 – 3”/50 – 80mm: 0.062”/1.6mm diameter perforations on 0.09”/2.3mm centers, 41% open area.
- 4 – 12”/100 – 300mm: 0.125”/3.2mm diameter perforations on 0.19”/4.8mm centers, 40% open area.

Gasket Grade: (specify choice*)†

- **Grade “E” EPDM**

EPDM (Green color code). Temperature range –30°F to +230°F/–34°C to +110°C. Recommended for cold and hot water service within the specified temperature range plus a variety of dilute acids, oil-free air and many chemical services. UL classified in accordance with ANSI/NSF 61 for cold +86°F/+30°C and hot +180°F/+82°C potable water service. NOT RECOMMENDED FOR PETROLEUM SERVICES.

JOB OWNER

System No. _____
 Location _____

CONTRACTOR

Submitted By _____
 Date _____

ENGINEER

Spec Sect _____ Para _____
 Approved _____
 Date _____

Wye Type Vic-Strainer®

SERIES 732

MATERIAL SPECIFICATIONS

• **Grade “T” nitrile**

Nitrile (Orange color code). Temperature range -20°F to +180°F/-29°C to +82°C. Recommended for petroleum products, air with oil vapors, vegetable and mineral oils within the specified temperature range. Not recommended for hot water services over +150°F/+66°C or for hot dry air over +140°F/+60°C.

*Services listed are General Service Recommendations only. It should be noted that there are services for which these gaskets are not recommended. Reference should always be made to the latest Victaulic Gasket Selection Guide for specific gasket service recommendations and for a listing of services which are not recommended.

† Supplemental lubricant is recommended for services installed at or continuously operating below 0°F/-18°C.

Bolts/Nuts: Heat treated carbon steel zinc electroplated to ASTM B-633, track head conforming to physical properties of ASTM A-183 minimum tensile 110,000psi/758340kPa.

Couplings: Series 732 Vic-Strainer is supplied with a Style 07 Zero-Flex® coupling for cleaning access.

Blow Down Port: An NPT tap is provided in the cap for a discharge valve connection allowing solids to be “blown down” while the system is in service. Strainer supplied with cap plugged.

Blow Down Drain Valve: DZR Brass. This option is available upon request and is only offered on sizes 2 ½”/65 mm, 3”/80mm, 4”/100 mm and 6”/150 mm.

Other: Special requirements can often be met. Contact Victaulic with specific requirements for recommendations, availability and delivery.

DIMENSIONS

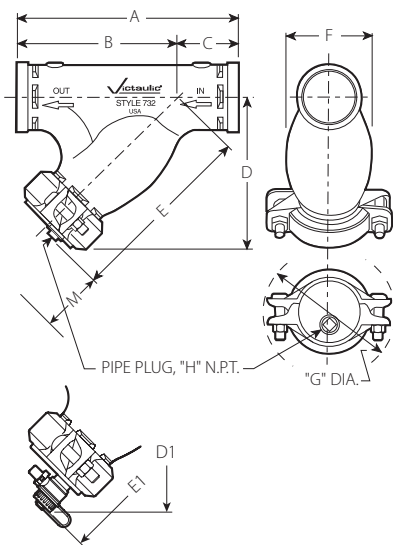

Size		Max. Work Pressure psi kPa	Dimensions – Inches/mm											Approx. Wgt. Each Lbs. kg
Nominal Size Inches/ mm	Actual Outside Diameter Inches/ mm		End to End A	B	C	D	D1	E	E1	F	G ²	H	M ³	
2 50	2.375 60.3	300 2065	9.75 248	7.00 178	2.75 70	7.54 192	–	8.54 217	–	3.31 84	5.78 146	0.50 13	6.25 158	10.0 4.5
2½ 65	2.875 73.0	300 2065	10.75 273	7.75 197	3.00 76	8.32 211	9.75 248	9.32 237	11.60 295	3.94 100	6.38 162	0.50 13	7.00 177	14.0 6.4
76.1 mm	3.000 76.1	300 2065	10.75 273	7.75 197	3.00 76	8.32 211	–	9.32 237	–	3.94 100	6.61 167	0.50 13	7.00 177	14.0 6.4
3 80	3.500 88.9	300 2065	11.75 299	8.50 216	3.25 83	9.08 231	10.40 264	10.14 258	12.15 309	4.64 117	6.81 173	0.75 19	7.83 198	20.0 9.1
4 100	4.500 114.3	300 2065	14.25 362	10.50 267	3.75 95	11.06 281	12.22 310	12.36 314	14.32 364	6.19 157	8.21 208	1.00 25	9.70 246	32.0 14.5
5 125	5.563 141.3	300 2065	16.50 419	12.50 318	4.00 102	13.00 330	–	14.36 365	–	7.73 196	9.89 251	1.00 25	12.00 304	50.0 22.7
6 150	6.625 168.3	300 2065	18.50 470	14.00 356	4.50 114	14.44 367	15.50 394	16.06 408	17.95 456	9.12 231	10.83 275	1.25 32	13.38 339	72.0 32.7
165.1 mm	6.500 165.1	300 2065	18.50 470	14.00 356	4.50 114	14.44 367	–	16.06 408	–	9.12 231	10.83 275	1.25 32	13.38 339	72.0 32.7
8 200	8.625 219.1	300 2065	24.00 610	18.00 457	6.00 152	18.38 467	–	20.50 521	–	12.24 310	13.74 349	1.50 38	17.44 443	125.0 56.7
10 250	10.750 273.0	300 2065	27.00 686	21.00 533	6.00 152	22.00 559	–	23.82 605	–	14.02 356	16.98 431	2.00 51	20.75 527	205.0 93.0
12 300	12.750 323.9	300 2065	30.00 762	24.50 622	5.50 140	24.75 629	–	27.37 695	–	16.89 429	18.88 479	2.00 51	24.50 622	280.0 127.0

¹ Working pressure is maximum and will be governed by couplings used for installation and related system components. Maximum differential pressure from inlet to outlet must not exceed 10 psi/69 kPa.

² Dimensions will vary depending upon coupling orientation.

³ Dimension M represents the minimum clearance required to remove the basket from the strainer.

Wye Type Vic-Strainer®

SERIES 732

PERFORMANCE

The charts below express the flow of water at 65°F/18°C.

FLOW CHARACTERISTICS

Flow characteristics are based on standard, clean baskets. Flow may vary from these figures.

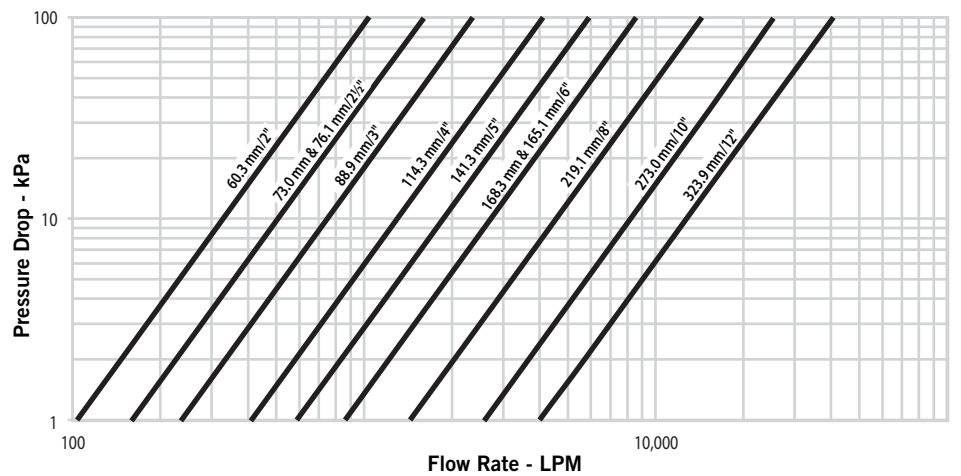
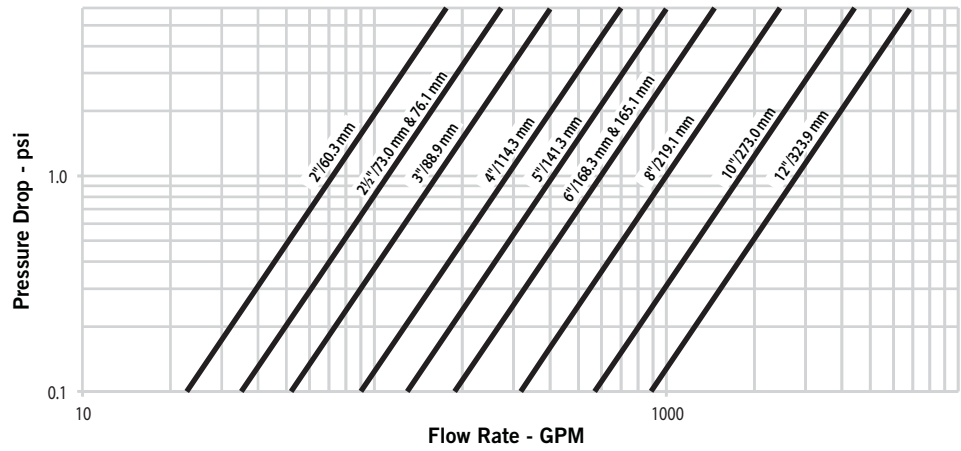

Wye Type Vic-Strainer®

SERIES 732

FLOW RATE

C_v/K_v values for flow of water at +60°F/+16°C are shown in tables below.

Formulas for C_v/K_v values:

$$\Delta P = \frac{Q^2}{C_v^2}$$

$$Q = C_v \times \sqrt{\Delta P}$$

Where:

Q = Flow (GPM)

ΔP = Pressure Drop (psi)

C_v = Flow Coefficient

$$\Delta P = \frac{Q^2}{K_v}$$

$$Q = K_v \times \sqrt{\Delta P}$$

Size		C _v /K _v	Size		C _v /K _v
Nominal Size Inches/mm	Actual Outside Diameter Inches/mm		Nominal Size Inches/mm	Actual Outside Diameter Inches/mm	
2	2.375	72	6	6.625	597
50	60.3	62	150	168.3	516
2½	2.875	111	165.1 mm	6.500	597
65	73.0	96		165.1	516
76.1 mm	3.000	111	8	8.625	1000
	76.1	96	200	219.1	865
3	3.500	164	10	10.750	1800
80	88.9	142	250	273.0	1557
4	4.500	285	12	12.750	2800
100	114.3	247	300	323.9	2422
5	5.563	410			
125	141.3	355			

WARRANTY

Refer to the Warranty section of the current Price List or contact Victaulic for details.

NOTE

This product shall be manufactured by Victaulic or to Victaulic specifications. All products to be installed in accordance with current Victaulic installation/assembly instructions. Victaulic reserves the right to change product specifications, designs and standard equipment without notice and without incurring obligations.