

AGS Vic-Ring® Systems



STYLE W77- Flexible Coupling

The patented Style W77 AGS (Advanced Groove System) coupling is comprised of two housings and is designed to provide a strong connection for large diameter pressure piping systems. Its unique wedge-shaped key results in easier initial assembly alignment. The Style W77 AGS coupling in 26 – 62"/660 – 1550 mm sizes, features lifting lugs integrated into the housings to help ease handling during installation.

The Style W77 coupling is mounted onto an external ring utilizing a patented AGS groove profile. The Vic-ring system provided by Victaulic maintains full pipe wall thickness for slurries, tailings, and a variety of other services.

Style W77 AGS couplings are rated up to 350psi/2400 kPa for 14 – 24"/350 – 600mm, up to 300 psi/2065 kPa for 26 – 44"/650 – 1100 mm, to 232 psi/1600 kPa for 46 – 50"/1150 – 1250 mm piping systems and to 175 psi/1200 kPa for 54 – 62"/1350 – 1550 mm. Style W77 AGS couplings provide limited linear and angular pipe movement at the pipe joint that can be used to compensate for thermal growth of piping systems, vibration attenuation, seismic, and other applications requiring flexibility. Support and hanging requirements are defined within Victaulic Design Data Submittal 26.01.

Style W77 AGS couplings are provided with FlushSeal® gaskets for a variety of services. Please specify gasket grade when ordering. Please refer to publication 05.01 for gasket service ratings.

Rigid couplings for Vic-Ring systems are also available. Refer to publication 16.11.



12 – 24"/300 – 600 MM SIZES PATENTED



26 – 62"/650 – 1550 MM SIZES PATENTED



WARNING

WARNING

- Victaulic AGS couplings **MUST ONLY** be installed on AGS Vic-ring systems provided by Victaulic.
- Failure to follow these instructions will cause grooves that are not within Victaulic AGS specifications, resulting in joint failure, serious personal injury, and property damage.

Pipe OD Requirements*	
Nominal Pipe Size	Maximum Pipe OD
In. / mm	In. / mm
12	12.88
300	327
14	14.14
350	359
16	16.16
400	410
18	18.18
450	462
20	20.20
500	513
24	24.25
600	616
26 – 62 650 – 1550	Nominal Pipe Size + 0.250"/6.4mm

* For pipe exceeding these values contact Victaulic.

JOB/OWNER

System No. _____
Location _____

CONTRACTOR

Submitted By _____
Date _____

ENGINEER

Spec Sect _____ Para _____
Approved _____
Date _____

AGS Vic-Ring® Systems

STYLE W77- Flexible Coupling

MATERIAL SPECIFICATIONS

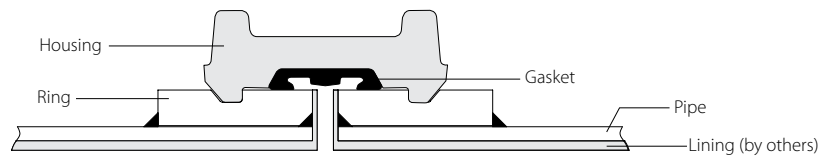

Vic-Rings: Type "D" Vic-Rings

- **Material**

Carbon Steel to ASTM A 105 or equivalent

* Optional: ASTM A105N (Specify at time of order)

Other materials available upon request. Contact Victaulic for details.

Housing: Ductile iron conforming to ASTM A-536, grade 65-45-12. Ductile iron conforming to ASTM A-395, grade 65-45-15, is available upon special request.

Housing Coating: Orange enamel.

- Optional: Hot dipped galvanized and others.

Coupling Gasket: (specify choice*)

- **Grade "E" FlushSeal EPDM**

EPDM (Green color code). Temperature range -30°F to $+230^{\circ}\text{F}$ / -34°C to $+110^{\circ}\text{C}$.

Recommended for cold and hot water service within the specified temperature range plus a variety of dilute acids, oil-free air and many chemical services. UL classified in accordance with ANSI/NSF 61 for cold $+86^{\circ}\text{F}/+30^{\circ}\text{C}$ and hot $+180^{\circ}\text{F}/+82^{\circ}\text{C}$ potable water service. NOT RECOMMENDED FOR PETROLEUM SERVICES.

- **Grade "T" FlushSeal nitrile**

Nitrile (Orange color code). Temperature range -20°F to $+180^{\circ}\text{F}$ / -29°C to $+82^{\circ}\text{C}$.

Recommended for petroleum products, air with oil vapors, vegetable and mineral oils within the specified temperature range. Not recommended for hot water services over $+150^{\circ}\text{F}/+66^{\circ}\text{C}$ or for hot dry air over $+140^{\circ}\text{F}/+60^{\circ}\text{C}$.

- **Grade "L" FlushSeal silicone**

Silicone (Red color code). Temperature range -30°F to $+350^{\circ}\text{F}$ / -34°C to $+177^{\circ}\text{C}$.

Recommended for dry heat, air without hydrocarbons to $+350^{\circ}\text{F}/+177^{\circ}\text{C}$ and certain chemical services.

* Services listed are General Service Recommendations only. It should be noted that there are services for which these gaskets are not recommended. Reference should always be made to the latest Victaulic Gasket Selection Guide for specific gasket service recommendations and for a listing of services which are not recommended.

Bolts: Heat-treated plated carbon steel, trackhead meeting the physical and chemical requirements of ASTM A-449 and physical requirements of ASTM A-183.

Nuts: Plated carbon steel, heavy hex conforming to ASTM A-563, Grade B.

Washers: Plated carbon steel, flat, SAE high strength conforming to ASTM F-436.

AGS Vic-Ring® Systems

STYLE W77- Flexible Coupling

DIMENSIONS

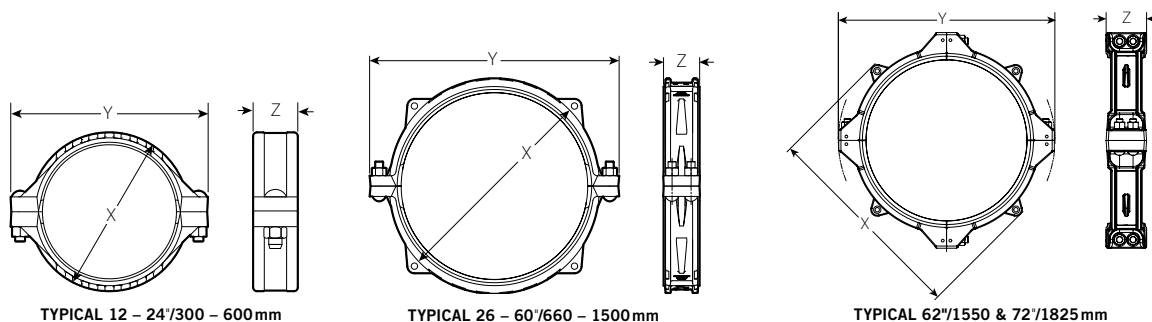

Size		Max. Working Pressure*	Max. End Load* Lbs./N On Vic-Ring	Allow. Pipe End Sep.	Deflect. From CL		Bolt/Nut No - Size	Dimensions – Inches/mm			Approx. Wgt. Each Coupling Only Lbs. kg
Nominal Pipe Size Inches mm	Coupling Size In./mm				psi/kPa	Inches mm		Per Cplg. Deg.	Pipe In./Ft. mm/m	Inches	
12 300	14.000 355.6	350 2500	53900 239757	0.13 – 0.31 3.3 – 7.9	0.73	0.15 13	2 – 1 x 5 1/2	16.00 406	20.63 524	4.50 114	48.0 21.8
14 350	16.000 406.4	350 2500	70400 313155	0.13 – 0.31 3.3 – 7.9	0.63	0.13 11	2 – 1 x 5 1/2	18.25 464	23.50 597	4.50 114	58.0 26.3
16 400	18.000 457.2	350 2500	89100 396335	0.13 – 0.31 3.3 – 7.9	0.57	0.12 10	2 – 1 x 5 1/2	20.38 517	25.50 647	4.50 114	65.0 29.5
18 450	20.000 508.0	350 2500	109950 489304	0.13 – 0.31 3.3 – 7.9	0.50	0.10 9	2 – 1 1/8 x 5 1/2	22.63 575	27.13 689	4.50 114	82.0 37.2
20 500	22.000 558.8	350 2500	133050 592075	0.13 – 0.31 3.3 – 7.9	0.50	0.10 9	2 – 1 1/8 x 6	24.75 628.7	29.25 743.0	4.50 114	99.0 44.9
22 550	24.000 609.6	350 2500	158336 704275	0.13 – 0.31 3.3 – 7.9	0.42	0.09 8	2 – 1 1/8 x 5 1/2	26.88 683	32.38 822	4.50 114	107.0 48.5
24 600	26.000 660.4	300 2065	159279 708508	0.15-0.53 3.81-13.46	0.83	0.18 15	4 – 1 1/8 x 6	30.13 765	35.25 895	5.75 146	205.0 93.0
26 650	28.000 711.2	300 2065	184726 821702	0.15-0.53 3.81-13.46	0.78	0.16 14	4 – 1 1/8 x 6	32.25 819	37.25 945	5.75 146	220.0 99.8
28 700	30.000 762.0	300 2065	212058 943281	0.15-0.53 3.81-13.46	0.73	0.16 14	4 – 1 1/4 x 7	33.88 863	39.63 1007	5.75 146	227.0 103.0
30 750	32.000 812.8	300 2065	241274 1073240	0.15-0.53 3.81-13.46	0.68	0.14 11	4 – 1 1/4 x 7	36.13 916	41.75 1060	5.75 146	242.0 109.8
32 800	34.000 865.0	300 2065	272375 1212070	0.15 - 0.53 3.81 - 13.46	0.69	0.13 11	4 – 1 1/4 x 7	38.25 972	43.75 1111	5.75 146	255.0 115.7
34 850	36.000 914.4	300 2065	305363 1358322	0.15-0.53 3.81-13.46	0.60	0.13 11	4 – 1 1/4 x 7	40.25 1022	45.75 1161	5.75 146	268.0 121.6
36 900	38.000 965.2	300 2065	340235 1513365	0.15-0.53 3.81-13.46	0.60	0.13 11	4 – 1 1/4 x 7	41.25 1048	48.00 1219	5.75 146	298.0 135.0
38 950	40.000 1016.0	300 2065	376991 1676940	0.21-0.59 5.33-14.99	0.55	0.12 10	4 – 1 1/2 x 7	44.00 1117	50.50 1283	6.50 165	340.0 154.2
40 1000	42.000 1066.8	300 2065	415632 1848823	0.21-0.59 5.33-14.99	0.52	0.11 9	4 – 1 1/2 x 8	46.00 1168	52.50 1334	6.50 165	360.0 163.3
42 1050	44.000 1150.0	232 1600	352763 1569795	0.21 - 0.59 5.33 - 14.99	0.5	0.10 8	4 – 1 1/2 x 8	48.00 1219	54.50 1384	6.50 165	390.0 176.9
44 1100	46.000 1168.4	232 1600	385561 1715746	0.21-0.59 5.33-14.99	0.47	0.10 8	4 – 1 1/2 x 8	50.25 1277	56.50 1435	6.50 165	415.0 188.2

* Working Pressure and End Load are total, from all internal and external loads, based on carbon steel, AGS rings installed in accordance with Victaulic specifications. Contact Victaulic for performance on other ring materials.

WARNING: FOR ONE TIME FIELD TEST ONLY, the Maximum Joint Working Pressure may be increased to 1 1/2 times the figures shown.

Metric thread size bolts are available (color coded gold) for all coupling sizes upon request. Contact Victaulic for details.

† Allowable Pipe End Separation and Deflection figures show the maximum nominal range of movement available at each joint for AGS roll grooved pipe.

These figures are maximums; for design and installation purposes these figures should be reduced by 25%.

NOTE: The Style W77 AGS Vic-Ring system is available for pipe sizes ranging from 12 - 60"/300 - 1500 mm. The coupling used to join these pipes will always be the next largest size (ex: 12"/300mm pipe requires the use of 14"/350 mm coupling). The larger size is needed to allow for the extra outside pipe diameter the AGS ring adds to the pipe.

AGS Vic-Ring® Systems

STYLE W77- Flexible Coupling

DIMENSIONS

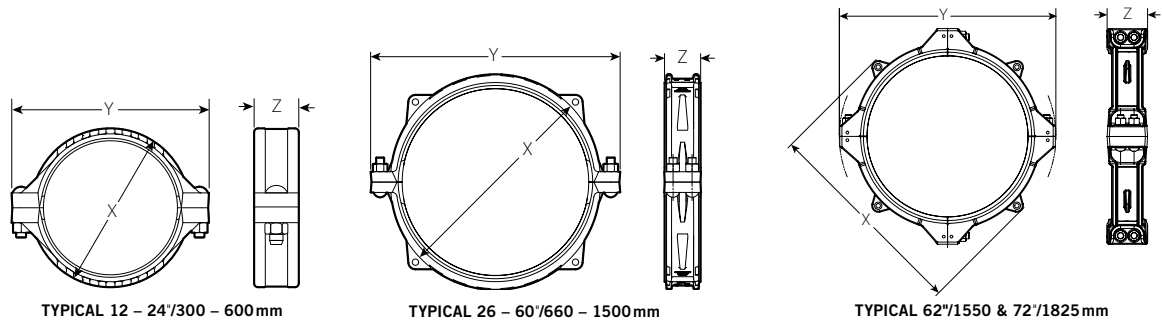

Size		Max. Working Pressure*	Max. End Load† Lbs./N	Allow. Pipe End Sep.	Deflect. From CL		Bolt/Nut No - Size	Dimensions – Inches/mm			Approx. Wgt. Each Coupling Only Lbs. kg
Nominal Pipe Size Inches mm	Coupling Size In./mm				Inches mm	Per Cplg. Deg.		Pipe In./Ft. mm/m	Inches	X	
46 1150	48.000 1219.2	232 1600	419820 1868199	0.21-0.59 5.33-14.99	0.45	0.10 8	4 – 1½ x 8	52.25 1328	58.50 1485	6.50 165	425.0 192.8
48 1200	50.000 1270.0	232 1600	455530 2026298	0.28-0.66 7.11-16.76	0.43	0.09 7.5	4 – 1½ x 8	53.63 1362	60.88 1546	10.00 254	500.0 227.0
52 1300	54.000 1371.6	175 1200	400790 1782803	0.28-0.66 7.11-16.76	0.40	0.08 7	4 – 1½ x 7	59.00 1499	65.13 1655	10.00 254	648.0 293.9
54 1350	56.000 1422.2	175 1200	431030 1917317	0.28-0.66 7.11-16.76	0.38	0.08 7	4 – 1½ x 7	61.00 1550	67.63 1718	10.00 254	676.0 306.6
58 1450	60.000 1524.0	175 1200	494800 2201025	0.28-0.66 7.11-16.76	0.36	0.08 7	4 – 1½ x 7	65.00 1652	72.13 1832	10.00 254	720.0 326.6
60 1500	62.000 1574.8	175 1200	528340 2350173	0.28-0.66 7.11-16.76	0.35	0.07 6	4 – 1½ x 7	67.28 1709	73.63 1870	10.00 254	956.0 433.6

* **Working Pressure** and **End Load** are total, from all internal and external loads, based on carbon steel, AGS rings installed in accordance with Victaulic specifications. Contact Victaulic for performance on other ring materials.

WARNING: FOR ONE TIME FIELD TEST ONLY, the Maximum Joint Working Pressure may be increased to 1 ½ times the figures shown.

Metric thread size bolts are available (color coded gold) for all coupling sizes upon request. Contact Victaulic for details.

† Allowable Pipe End Separation and Deflection figures show the maximum nominal range of movement available at each joint for AGS roll grooved pipe.

These figures are maximums; for design and installation purposes these figures should be reduced by 25%.

NOTE: The Style W77 AGS Vic-Ring system is available for pipe sizes ranging from 12 - 60 inch (300 - 1500 mm). The coupling used to join these pipes will always be the next largest size (ex: 12 inch (300mm) pipe requires the use of 14 inch (350 mm) coupling). The larger size is needed to allow for the extra outside pipe diameter the AGS ring adds to the pipe.

AGS Vic-Ring® Systems

STYLE W77- Flexible Coupling

LINING OPTIONS

UNLINED SERVICES*

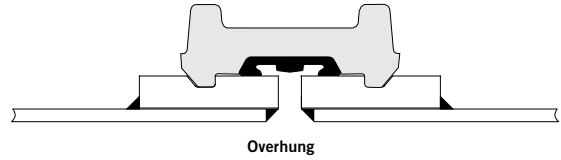
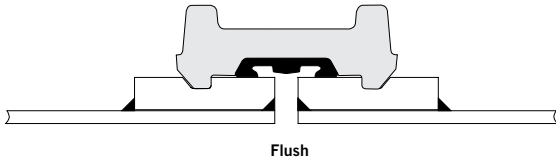

ABRASION SERVICES

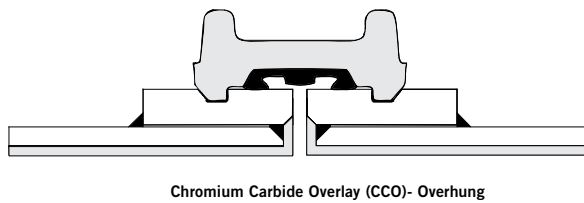
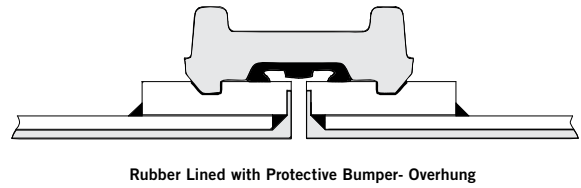
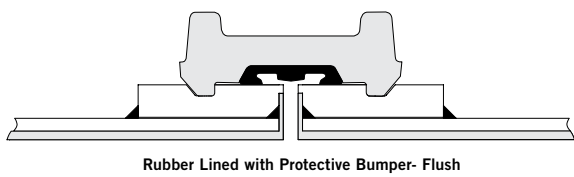
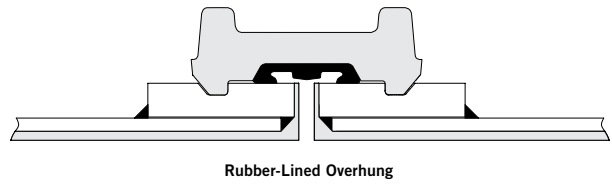
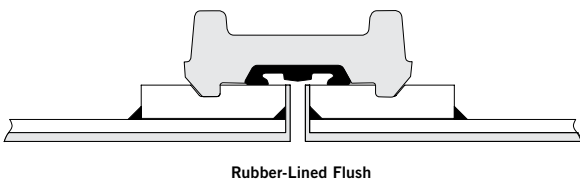

ABRASION AND CORROSION SERVICES

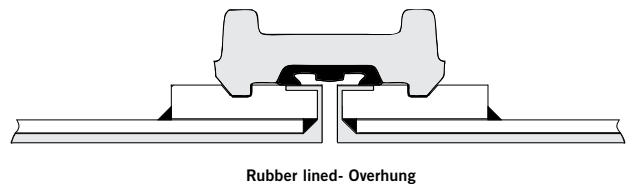
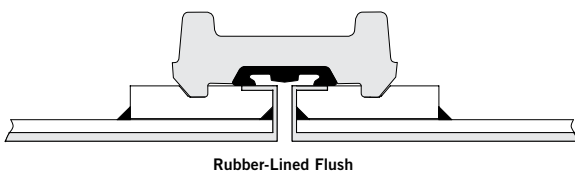

*Suitable for use on abrasive and non-abrasive services

AGS Vic-Ring® Systems

STYLE W77- Flexible Coupling

ALL SERVICE OPTIONS

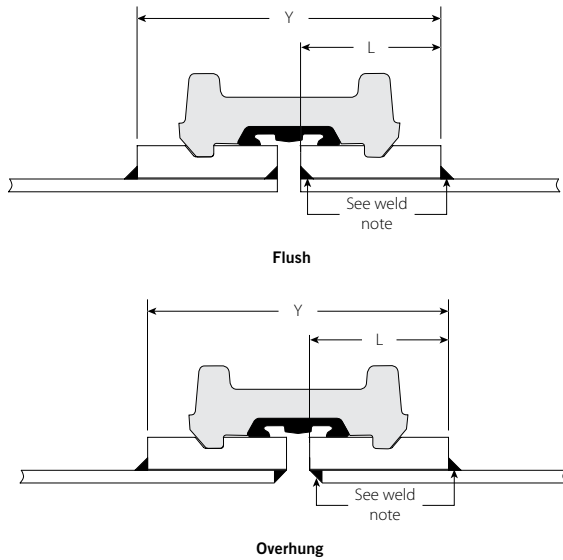

Size			AGS Vic-Ring		
Nominal Size In./mm	Coupling Size In./mm	O.D. Ring Size In./mm	L [†] In./mm	Y [†] In./mm	Approx. Ring Weight Each Lbs./kg
12 300	14.000 355.6	14.000 355.6	3.00 76.2	6.13 - 6.31 155.7 - 160.3	19.0 8.6
14 350	16.000 406.4	16.000 406.4	3.00 76.2	6.13 - 6.31 155.7 - 160.3	37.0 16.8
16 400	18.000 457.2	18.000 457.2	3.00 76.2	6.13 - 6.31 155.7 - 160.3	41.0 18.6
18 450	20.000 508.0	20.000 508.0	3.00 76.2	6.13 - 6.31 155.7 - 160.3	46.0 20.9
20 500	22.000 558.8	22.000 558.8	3.00 76.2	6.13 - 6.31 155.7 - 160.3	51.0 23.1
22 550	24.000 609.6	24.000 609.6	3.00 76.2	6.13 - 6.31 155.7 - 160.3	56.0 25.4
24 600	26.000 660.4	26.000 660.4	4.00 101.6	8.15 - 8.53 207.0 - 216.7	81.0 36.7
26 650	28.000 711.2	28.000 711.2	4.00 101.6	8.15 - 8.53 207.0 - 216.7	87.0 39.5
28 700	30.000 762.0	30.000 762.0	4.00 101.6	8.15 - 8.53 207.0 - 216.7	94.0 42.6
30 750	32.000 812.8	32.000 812.8	4.00 101.6	8.15 - 8.53 207.0 - 216.7	100.0 48.4
32 800	34.000 865.0	34.000 865.0	4.00 101.6	8.21 - 8.59 208.5 - 218.2	107.0 48.5
34 850	36.000 914.4	36.000 914.4	4.00 101.6	8.15 - 8.53 207.0 - 216.7	113.0 51.3
36 900	38.000 965.2	38.000 965.2	4.00 101.6	8.15 - 8.53 207.0 - 216.7	120.0 54.4
38 950	40.000 1016.0	40.000 1016.0	4.25 108.0	8.71 - 9.09 221.2 - 230.9	133.0 60.3
40 1000	42.000 1066.8	42.000 1066.8	4.25 108.0	8.71 - 9.09 221.2 - 230.9	140.0 63.5
42 1050	44.000 1150.0	44.000 1150.0	4.25 108.0	8.71 - 9.09 221.2 - 230.9	146.0 66.2
44 1100	46.000 1168.4	46.000 1168.4	4.25 108.0	8.71 - 9.09 221.2 - 230.9	152.0 69.0
46 1150	48.000 1219.2	48.000 1219.2	4.25 108.0	8.71 - 9.09 221.2 - 230.9	160.0 72.6
48 1200	50.000 1270.0	50.000 1270.0	4.25 108.0	8.71 - 9.09 221.2 - 230.9	186.0 84.4
52 1300	54.000 1371.6	54.000 1371.6	5.00 127.0	10.28 - 10.66 261.1 - 270.8	215.0 97.5
54 1350	56.000 1422.2	56.000 1422.2	5.00 127.0	10.28 - 10.66 261.1 - 270.8	223.0 101.2
58 1450	60.000 1524.0	60.000 1524.0	5.00 127.0	10.28 - 10.66 261.1 - 270.8	239.0 108.4
60 1500	62.000 1574.8	62.000 1574.8	5.00 127.0	10.28 - 10.60 261.1 - 270.8	270.0 122.5

Weld Note: Minimum recommended weld size is 3/8"/9.7 mm for 14"/350 mm and larger standard and extra heavy pipe. For 12"/300 mm pipe the minimum recommended weld size is 1/4"/6.4 mm

† For allowable pipe end separation see dimensional table on page 3.

‡ "L" dimension is from inside face to end of ring for all lined and un-lined configurations.

AGS Vic-Ring® Systems

STYLE W77- Flexible Coupling

TORQUE REQUIREMENTS

Size	Recommended Torque
Nominal Size Inches mm	ft. lbs. N•m
12, 14, 16, 18 300, 350, 400, 450	250 340
20, 22, 24, 26, 28 500, 550, 600, 650, 700	375 500
30, 32, 34, 36, 38 750, 800, 850, 900, 950	500 680
40, 42, 44, 46, 48, 50, 54, 56, 60, 62 1000, 1050, 1100, 1150, 1200, 1250, 1350, 1400, 1500, 1550	600 813

INSTALLATION

Reference should always be made to the Victaulic Field Installation Instructions for the product you are installing. Victaulic Field Installation Instructions are included with each shipment of Victaulic products for complete installation and assembly data, and are available in PDF format on our website at www.victaulic.com.

WARRANTY

Refer to the Warranty section of the current Price List or contact Victaulic for details.

NOTE

This product shall be manufactured by Victaulic or to Victaulic specifications. All products to be installed in accordance with current Victaulic installation/assembly instructions. Victaulic reserves the right to change product specifications, designs and standard equipment without notice and without incurring obligations.

For complete contact information, visit www.victaulic.com

16.12 6322 REV H UPDATED 06/2013

VICTAULIC IS A REGISTERED TRADEMARK OF VICTAULIC COMPANY. © 2013 VICTAULIC COMPANY. ALL RIGHTS RESERVED.

16.12

