



**UL, ULC, and FM Approved**

**Sizes Available:** 6" (150mm), 8" (200mm) and 10" (250mm)

**Voltages Available:** 24VAC  
120VAC  
12VDC (10.2 to 15.6) Polarized  
24VDC (20.4 to 31.2) Polarized

**Service Use:** Fire Alarm  
General Signaling  
Burglar Alarm

**Environment:** Indoor or outdoor use (See Note 1)  
-40° to 150°F (-40° to 66°C)  
(Outdoor use requires weatherproof  
backbox.)

**Termination:** AC Bells - 4 No. 18 AWG stranded wires  
DC Bells - Terminal strip

**Finish:** Red powder coating

**Optional:** Model BBK-1 weatherproof backbox  
Model BBX-1 deep weatherproof backbox



These vibrating type bells are designed for use as fire, burglar or general signaling devices. They have low power consumption and high decibel ratings. The unit mounts on a standard 4" (101mm) square electrical box for indoor use or on a model BBK-1 weatherproof backbox for outdoor applications. Weatherproof backbox model BBK-1, Stock No. 1500001.

ALL DC BELLS ARE POLARIZED AND HAVE BUILT-IN TRANSIENT PROTECTION:

Size inches (mm)	Voltage	Model Number	Stock Number	Current (Max.)	Typical dB at 10 ft. (3m) (2)	Minimum dB at 10 ft. (3m) (1)
6 (150)	12VDC	MBA126	1750070	.12A	85	76
8 (200)	12VDC	MBA128	1750080	.12A	90	77
10 (250)	12VDC	MBA1210	1750060	.12A	92	78
6 (150)	24VDC	MBA246	1750100	.06A	87	77
8 (200)	24VDC	MBA248	1750110	.06A	91	79
10 (250)	24VDC	MBA2410	1750090	.06A	94	80
6 (150)	24VAC	PBA246	1806024	.17A	91	78
8 (200)	24VAC	PBA248	1808024	.17A	94	77
10 (250)	24VAC	PBA2410	1810024	.17A	94	78
6 (150)	120VAC	PBA1206	1806120	.05A	92	83
8 (200)	120VAC	PBA1208	1808120	.05A	99	84
10 (250)	120VAC	PBA12010	1810120	.05A	99	86

**Notes:**

1. Minimum dB ratings are calculated from integrated sound pressure measurements made at Underwriters Laboratories as specified in UL Standard 464. UL temperature range is -30° to 150°F (-34° to 66°C).
2. Typical dB ratings are calculated from measurements made with a conventional sound level meter and are indicative of output levels in an actual installation.

**DIMENSIONS  
INCHES (mm)**

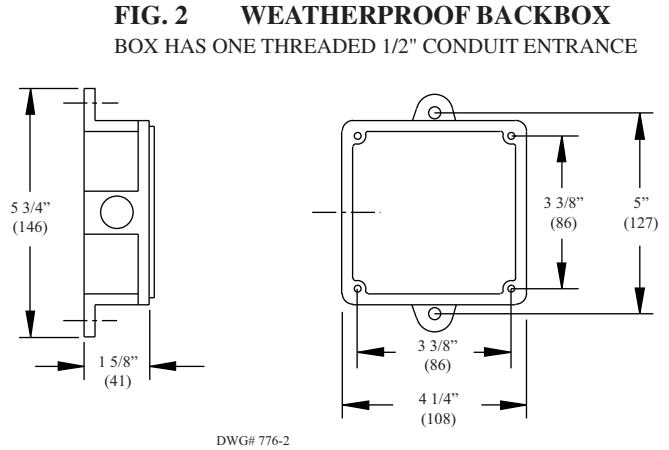
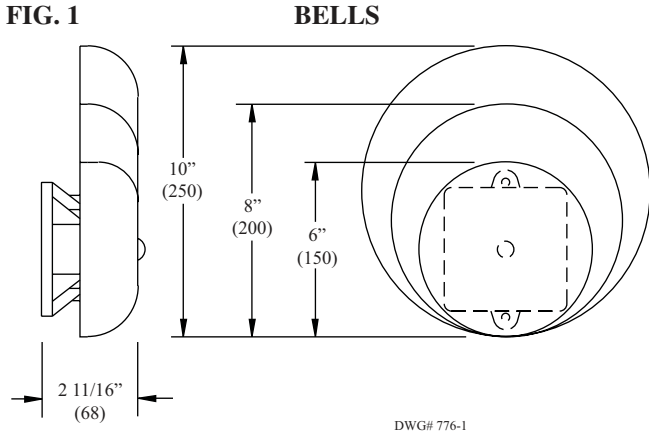

**FIG. 3**

**WIRING (REAR VIEW)**

**A.C. BELLS**

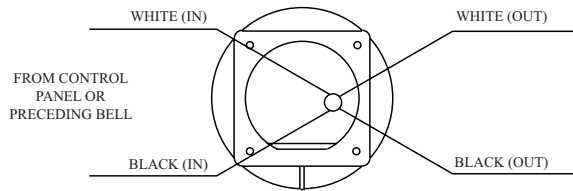
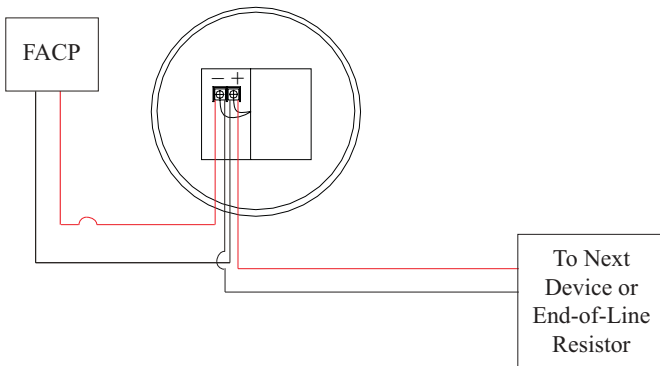

**CAUTION:**  
WHEN ELECTRICAL SUPERVISION IS REQUIRED USE IN AND OUT LEADS AS SHOWN.

**NOTES:**

1. WHEN USING AC BELLS, TERMINATE EACH EXTRA WIRE SEPARATELY AFTER LAST BELL.
2. END-OF-LINE RESISTOR IS NOT REQUIRED ON AC BELLS.

DWG# 776-3

**INSTALLATION**

1. The bell shall be installed in accordance with NFPA 13, 72, or local AHJ. The top of the device shall be no less than 90" AFF and not less than 6" below the ceiling.
2. Remove the gong.
3. Connect wiring (see Fig. 3).
4. Mount bell mechanism to backbox (bell mechanism must be mounted with the striker pointing down).
5. Reinstall the gong (be sure that the gong positioning pin, in the mechanism housing, is in the hole in the gong).
6. Test all bells for proper operation and observe that they can be heard where required (bells must be heard in all areas as designated by the authority having jurisdiction).