

Features

- Compatible with conventional 2-wire smoke detectors
- IDC can be wired One (1) Class A or Two (2) Class B
- Monitors presence of 24VDC Aux Power
- SLC Class A, Class X & Class B
- Mounts in a standard 4" or double gang box
- Wiring terminals accessible when mounted in box
- All wiring terminals accept 22 to 12AWG
- Product includes a 5 year warranty



Description

The PAD100-ZM module uses one (1) address on an SLC Loop when monitoring two (2) Class B or one (1) Class A circuit. The module requires and supervises a 24VDC auxiliary power connection. The 24VDC power source must be either a Potter IPA series addressable panel, or a Potter PSN series power supply. The IDC may be wired Class B or Class A which is selectable by an on board DIP switch. The PAD100-ZM employs one red LED to indicate the module's status. In normal condition, the LED flashes when the device is being polled by the control panel. When a device is activated, the LED will flash at a fast rate.

Application

The PAD100-ZM is compatible with Potter's IPA series addressable fire alarm control panels. The PAD100-ZM is used to supervise a zone of conventional 2-wire smoke detectors on an Initiating Device Circuit (IDC). The PAD100-ZM is capable of monitoring two (2) separate Class B or one (1) Class A circuits.

Setting the Address

Each addressable SLC device must be assigned an address. The address is set using the DIP switch located on the PAD100-ZM. When the PAD100-ZM is used to monitor two individual Class B circuits a single device address is assigned, each input is then identified as a sub-point of the module address. For example, if the address number is assigned as "8", the B1 input will be "8.1" and the B2 input will be "8.2".

Before connecting a device to the SLC loop, take the following precautions to prevent potential damage to the panel or device:

1. Power to the device is removed.
2. Field wiring is correctly installed.
3. Field wiring has no open or short circuits.

Technical Specifications

Operating Voltage	24.0V
Max SLC Standby Current	240 μ A
Max SLC Alarm Current	240 μ A
Aux Power Required	19 - 28V
Max Detector Standby Current of IDC at 24 VDC	1mA
Max Module Alarm Current of IDC at 24 VDC	50mA
Max Wiring Resistance of IDC	100 Ω
Max Wiring Capacitance of IDC	1 μ F
EOL Resistor	5.1K Ω
Operating Temperature Range	32 to 120°F (0 to 49°C)
Operating Humidity Range	0 to 93% (non-condensing)
Max no. of Module Per Loop	127 units
Dimensions	4.17" (106mm)L \times 4.17" (106mm)W \times 1.14" (29mm)D
Mounting Options	Standard 4" Square or Double Gang Box
Shipping Weight	0.6 lbs

Installation Using Compatible Electrical Box

Fig 1

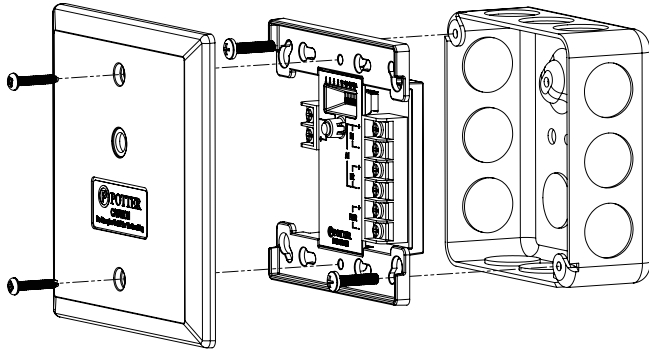

Wiring Diagrams

Typical Class B Wiring Diagram

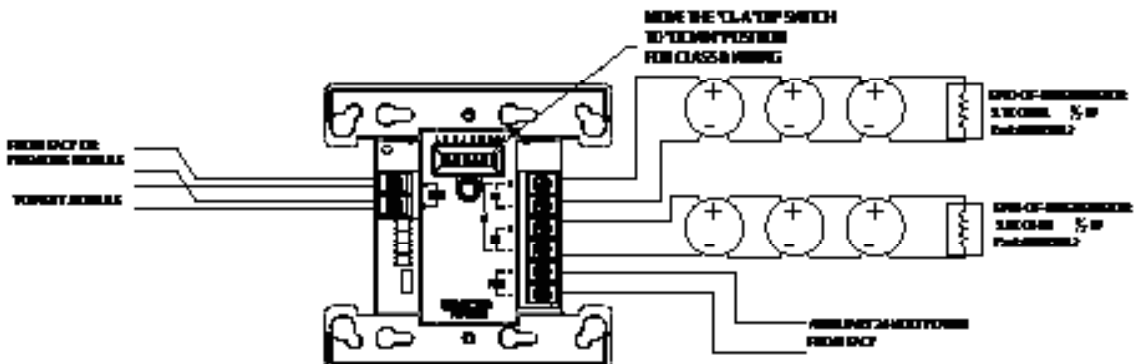

Typical Class A Wiring Diagram

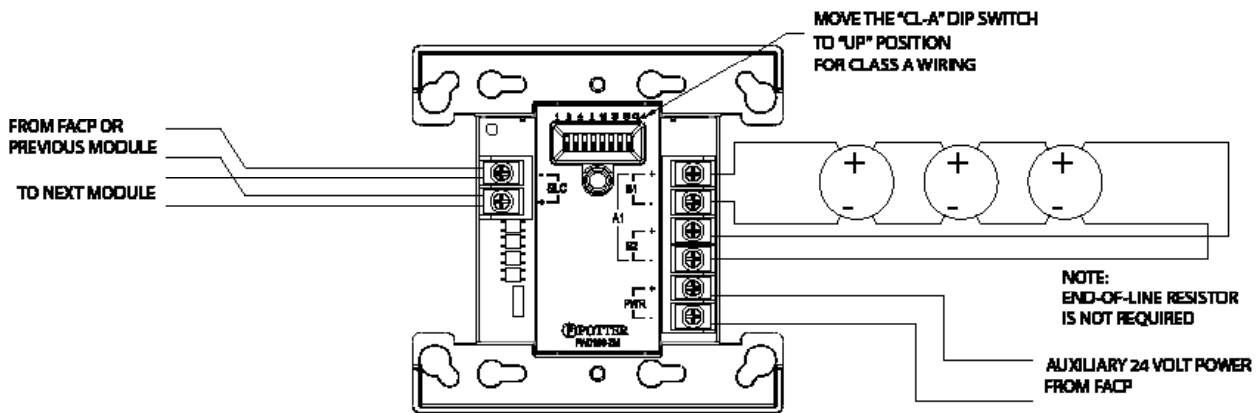

Ordering Information

Model	Description	Stock No.
PAD100-ZM	Conventional Zone Module	3992706

Compatible 2-Wire Smoke Detectors & Bases

Detector Model	Identifier	Base Model	Identifier
SYSTEM SENSOR (Brk) (Max. No. Of Detectors Per Zone is 10)			
1400	A	N/A	N/A
2400	A	N/A	N/A
2400TH	A	N/A	N/A
2W-B	A	N/A	N/A
2WT-B	A	N/A	N/A
DETECTION SYSTEM (Max. No. Of Detectors Per Zone is 11)			
DS250	A	MB2W/MB2WL	A
DS250TH	A	MB2W/MB2WL	A
ESL (Max. No. Of Detectors Per Zone is 20)			
611U	S10	601U	S00
611UD	S10	601U	S00
611UT	S10	601U	S00
612U	S10	601U	S00
612UD	S10	601U	S00
613U5	S10	601U	S00
611UD	S10	609U10	S00
612UD	S10	609U10	S00
425C	S10	N/A	N/A
425CT	S10	N/A	N/A
HOCHIKI (Max. No. Of Detectors Per Zone is 20)			
SLR-24	HD-3	HSC-221R	HB-71
		HSB-221	HB-54
		HSB-221N	HB-54
		NS6-221	
		NS4-221	
SLR-24H	HD-3	NS6-220	HB-3
		HSC-221R	HB-71
		HSB-221	HB-54
		HSB-221N	HB-54
		NS6-221	
SIJ-24	HD-3	NS4-221	
		HSC-221R	HB-71
		HSB-221	HB-54
		HSB-221N	HB-54
		NS6-221	
		NS4-221	

Detector Model	Identifier	Base Model	Identifier
FENWAL (Max. No. Of Detectors Per Zone is 14)			
CPD-7051	I51FE1	2-WIRE	FE51A
PSD-7155	P55FE1	2WRLT	FE52A
PSD-7156	P56FE1	2WRB	FE55A
All of the above Fenwal detectors and bases can be used in any combination. Retrofit Base Adaptor 70-501000-003, Identifier MAFE1 (for series 70-201000 Bases, Models -001, -002, -003, and -005). Duct Housing with Detector Base DH-51, Identifier DH22FE5 (for CPD-7051 and PSD-7155 detectors only).			
POTTER (Max. No. Of Detectors Per Zone is 25)			
PS-24	HD-3 (HOCHIKI)	SB-46	HB-71(HOCHIKI)
			HB-54 (HOCHIKI)
		SB-93	HB-3 (HOCHIKI)
PS-24H	HD-3 (HOCHIKI)	SB-46	HB-71 (HOCHIKI)
			HB-54 (HOCHIKI)
IS-24	HD-3 (HOCHIKI)	SB-46	HB-71 (HOCHIKI)
			HB-54 (HOCHIKI)
NOTE: If using a mix of System Sensor and other smoke detectors, a maximum of 20 detectors shall be permitted.			