

Reliable®

Model DDX-SS Deluge Valve 4" (100mm), 6" (150mm) & 8" (200mm)

Features

1. Differential Latch-type, lightweight, dependable construction.
2. Easily trimmed for releasing by:
 - Manual pull stations
 - Wet pilot sprinklers
 - Dry pilot actuators
 - Solenoid valves
3. Screw in seat & clapper assembly simplifies maintenance.
4. Stainless steel construction to resist corrosion.
5. Pressure-actuated clapper facing provides dependable seal.
6. Reset externally. Cover removal is not required.
7. Grooved or Flanged inlet and outlet connections.
8. Drain valve to drain standing water column.
9. Valve latches in open position. No pressure operated relief valve is required.
10. Pressure rating of 250 psi (17,2 bar).

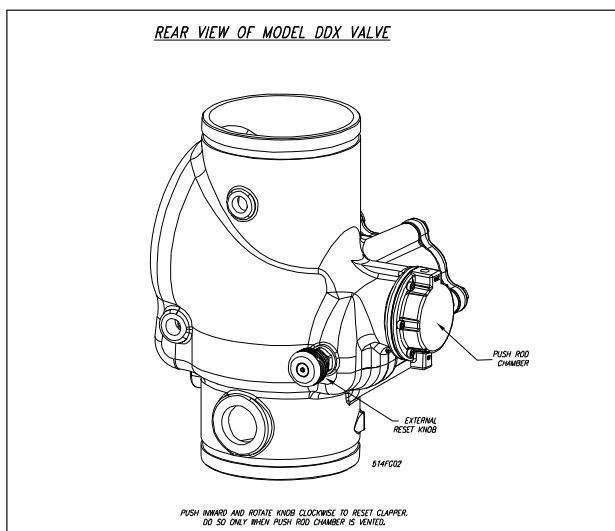

Fig. 2



Fig. 1

Listings & Approvals

(Only when used with Reliable's Trim Sets.)

1. Listed by Underwriters Laboratories, Inc. and UL certified for Canada (cULus).
2. Certified by Factory Mutual Approvals (FM).

The Reliable Model DDX-SS Deluge Valve is a hydraulically operated, latching clapper-type valve used to control the water supply to a deluge or preaction system. Deluge systems use open sprinklers or nozzles as discharge outlets in the fire area, while preaction systems use closed sprinklers or nozzles. Both systems use separate detection devices to control the operation of the Deluge Valve. Three simple trim arrangements allow for actuation of the

Reliable Model DDX-SS Deluge Valve by utilizing manual, hydraulic, pneumatic, or electrical devices. These devices include break glass stations, wet pilot sprinklers, dry pilot sprinklers, thermal detectors, and smoke detectors.

The Reliable Model DDX-SS Deluge Valve can be reset externally, without cover removal. This is accomplished by pushing in and turning the external reset knob at the rear of the Deluge Valve (see Fig. 2).

Valve Operation

The Reliable Model DDX-SS Deluge Valve is shown in both closed and open positions in Fig. 3. In the closed position, the supply pressure acts on the underside of the clapper and also on the push rod through the push rod chamber's inlet restriction. The resultant force due to the supply pressure acting on the push rod is multiplied by the mechanical advantage of the lever and is more than sufficient to hold the clapper closed against normal supply pressure surges.

When a fire is detected, a releasing device vents the push rod chamber to atmosphere through the chamber's outlet. Since the pressure cannot be replenished through the inlet restriction as rapidly as it is vented, the push rod chamber pressure falls instantaneously. When the push rod chamber pressure approaches approximately one third of the supply pressure, the upward force of the supply pressure acting beneath the clapper overcomes the lever-applied force thereby opening the clapper.

Once the clapper has opened, the lever acts as a latch, preventing the clapper from returning to the closed position. Water from the supply flows through the Deluge Valve into the system piping. Water also flows through the Deluge Valve's alarm outlet to the alarm devices.

After system shutdown, resetting the Model DDX-SS Deluge Valve is quite simple. Doing so only requires pushing in and turning the reset knob at the rear of the valve (see Fig. 2). The external reset feature of the Model DDX-SS Deluge Valve provides a means for simple, economical system testing, which is one essential facet of a good maintenance program. The external reset feature does not, however, eliminate another important facet of good maintenance, namely, periodic cleaning and inspection of the internal valve parts.

In the event that water builds up inside the valve due to condensate from the air supply system, or water left inside from valve system testing, a drain is available for venting. After closing the main supply valve, a small valve over the drain cup can be opened slightly until the water inside the valve body and the main pipe column has drained.

Whenever ambient temperature conditions are high, the water temperature in the Model DDX-SS Deluge Valve's pushrod chamber could possibly increase, thereby increasing the pressure in the chamber to values exceeding the rated pressure of the system. In an indoor installation where standard room temperatures are exceeded, a pressure relief kit may be needed. Pressure relief kit, P/N 6503050001, can be installed into the pushrod chamber's releasing line to limit the pressure to 250 psi (17,2 bar).

Reliable Model DDX-SS Deluge Valve with associated trim size [4" (100mm)][6" (150mm)][8" (200mm)], is rated for use at a minimum water supply pressure of 20 psi (1,4 bar) and a maximum water supply pressure of 250 psi (17,2 bar). Water supplied to the inlet of the valve and to the push rod chamber must be maintained between 40°F (4°C) and 140°F (60°C).

Detection and Actuation

In general, the Reliable Model DDX-SS Deluge Valve can be released by any Reliable UL Listed or FM Approved device that opens sufficiently to vent the push rod chamber in response to a fire. The releasing device is simply connected to the push rod chamber's outlet. When the releasing device operates and vents the push rod chamber, the Deluge Valve opens.

Typical releasing devices include hydraulic manual emergency stations, Model F1-FTR Fixed Temperature Detectors on wet pilot lines, dry pilot actuators, and solenoid valves. Model F1-FTR Detectors perform both Deluge Valve releasing and fire detection functions with wet pilot lines.

The use of a solenoid valve for Deluge Valve releasing enables various types of electrical fire detection devices to be used. Typical detection devices include electrical emergency pull stations, thermal detectors, and ionization or photoelectric smoke detectors. Electrical detection and releasing equipment used in Electrical Systems is described in Bulletins 700 and 722, for both deluge and preaction systems.

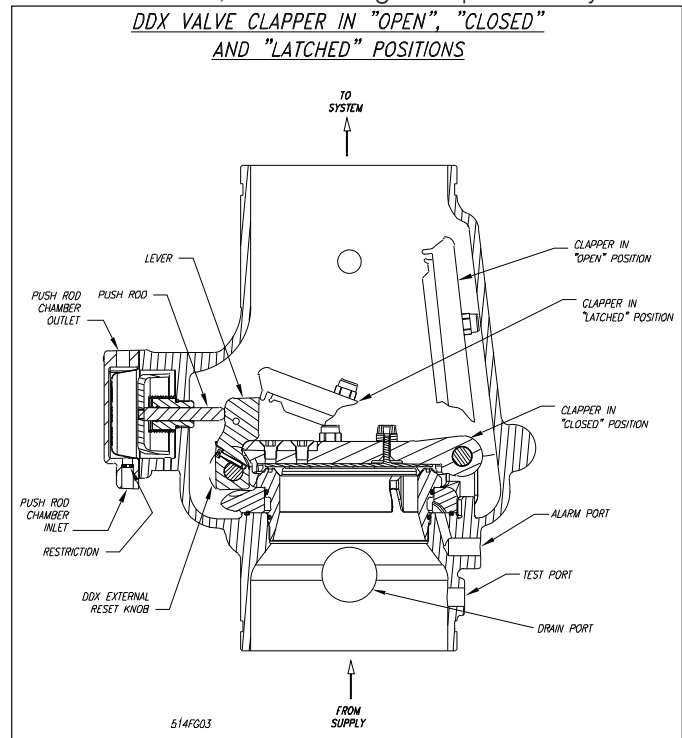

Fig. 3

Model DDX-SS Deluge Valve Description

1. Rated working pressure:
Valve & System - 250 psi (17.2 bar).
2. Factory tested to a hydrostatic pressure of 500 psi (34,5 bar). (Valve only)
3. End and trim connections:
 - ANSI/AWWA C606 grooved inlet and outlet

| Groove Dimension | | | | |
|-------------------|-------------------|-------------------|-----------------|-----------------------|
| Nominal Pipe Size | Outlet Diameter | Groove Diameter | Groove Width | Outlet Face to Groove |
| 4" | 4.500" (114mm) | 4.334" (110mm) | 3/8" (9.5mm) | 5/8" (16mm) |
| 6" | 6.625" (168mm) | 6.455" (164mm) | 3/8" (9.5mm) | 5/8" (16mm) |
| 8" | 8.625" (219mm) | 8.441" (214mm) | 7/16" (11mm) | 3/4" (19mm) |

- ASME B16.5 Flanged inlet and outlet

| Nominal Pipe Size | Flange Dimensions | | | | | Recommended Bolt Length | |
|-------------------|-------------------|----------------|--------------------|-----------------|---------------|-------------------------|-----------------|
| | Class Rating | Bolt Circle | Bolt Hole Diameter | Number of Bolts | Bolt Diameter | Machine Bolt | Stud Bolt |
| 4" | 150 | 7.50" (191mm) | 3/4" (19.1mm) | 8 | 5/8" (16mm) | 3.50" (88.9mm) | 4.00" (101.6mm) |
| | 300 | 7.88" (200mm) | 7/8" (22.2mm) | 8 | 3/4" (19.1mm) | 3.75" (95.3mm) | 4.50" (114.3mm) |
| 6" | 150 | 9.50" (241mm) | 7/8" (22.2mm) | 8 | 3/4" (19.1mm) | 3.75" (95.3mm) | 4.50" (114.3mm) |
| | 300 | 10.62" (270mm) | 7/8" (22.2mm) | 12 | 3/4" (19.1mm) | 4.25" (108.0mm) | 4.75" (120.7mm) |
| 8" | 150 | 11.75" (298mm) | 7/8" (22.2mm) | 8 | 3/4" (19.1mm) | 4.00" (101.6mm) | 4.75" (120.7mm) |
| | 300 | 13" (330mm) | 1" (25.4mm) | 12 | 7/8" (22.2mm) | 4.75" (120.7mm) | 5.50" (139.7mm) |

Note: Due to thickness of flange, the Class 150 bolt length is 1/2" (12.7 mm) longer than normally recommended per ASME B16.5

- Threaded openings Per ANSI B 2.1

- Valve Exterior's Color: Natural
- Face to Face Dimensions:

| Nominal Pipe Size | Groove/Groove | Flange/Flange |
|-------------------|--|--|
| 4" | 14" (356mm) | 16" (406mm) |
| 6" | 16" (406mm) | 18" (457mm) |
| 8" | 19 ³ / ₈ " (492mm) | 21 ¹ / ₄ " (540mm) |

- Shipping weight:

| Valve Shipping Weight | | |
|---------------------------|------------------|--------------------|
| 4" | Grv/Grv | 68 lbs (30,8 kg) |
| | Flg/Flg | 110 lbs (49,9 kg) |
| 6" | Grv/Grv | 101 lbs (45,8 kg) |
| | Flg/Flg | 170 lbs (77,1 kg) |
| 8" | Grv/Grv | 159 lbs (72,1 kg) |
| | Flg/Flg | 259 lbs (117,5 kg) |
| Trim Shipping Weight | | |
| Trim Configuration | Weight | |
| Wet Pilot Deluge | 32 lbs (14,5 kg) | |
| Dry Pilot Deluge | 43 lbs (19,5 kg) | |
| Electric Actuation Deluge | 34 lbs (15,4 kg) | |

- Friction loss (Expressed in equivalent length of Schedule 40 pipe, based on Hazen & Williams formula with C=120:

| Valve Size | Equivalent Length |
|------------|-------------------|
| 4" (100mm) | 14.9 ft (4,54 m) |
| 6" (150mm) | 31.8 ft (9,69 m) |
| 8" (200mm) | 53.5 ft (16,31 m) |

- Installation position: Vertical

Trim Descriptions

The trims for the Reliable Model DDX-SS Deluge Valve are arranged for rapid, easy, and compact attachment, and serve as connection points to Reliable Model C Mechanical Alarms and other devices. All Model DDX-SS Trim sets are available in 304 stainless steel or 316 stainless steel versions. The available Model DDX-SS Deluge Valve trim sets are:

- Wet Pilot Trim
- Dry Pilot Trim
- Electric Actuation Trim

The Wet Pilot Trim (see Fig. 4) is used when wet pilot sprinklers or hydraulic manual emergency pull boxes are used for detection and releasing. This trim set provides a two inch main drain, alarm test, supply pressure gauge, push rod chamber pressure gauge, push rod chamber supply connections, Model B-SS Hydraulic Manual Emergency Station, and a connection for releasing devices.

The Dry Pilot Trim (see Fig. 5) is used when dry pilot sprinklers are used as the fire detection means. This trim set includes the Model LP-SS Dry Pilot Line Actuator, air and water pressure gauges, low air pressure switch (for Dry Pilot Line), air pressure relief valve, connections for the air supply and pilot sprinkler lines, a two inch main drain, alarm test, push rod chamber connections, push rod chamber pressure gauge, and the Model B-SS Hydraulic Manual Emergency Station. Table A provides the recommended air pressure when the dry pilot trim set is used as the actuation means.

Table A

| Water Pressure psi (bar) | | Pneumatic Pressure to be Pumped into Sprinkler System psi (bar) | | | |
|--------------------------|--------|---|-------|---------------|-------|
| Maximum | | Not Les Than | | Not More Than | |
| 20 | (1.4) | 10 | (.7) | 14 | (1.) |
| 50 | (3.4) | 12 | (.8) | 16 | (1.1) |
| 75 | (5.2) | 13 | (.9) | 17 | (1.2) |
| 100 | (6.9) | 15 | (1.) | 19 | (1.3) |
| 125 | (8.6) | 16 | (1.1) | 20 | (1.4) |
| 150 | (10.3) | 17 | (1.2) | 21 | (1.4) |
| 175 | (12.1) | 18 | (1.2) | 22 | (1.5) |
| 200 | (13.8) | 19 | (1.3) | 23 | (1.6) |
| 225 | (15.5) | 21 | (1.4) | 25 | (1.7) |
| 250 | (17.2) | 22 | (1.5) | 26 | (1.8) |

***Note:** During system set-up, a higher pneumatic pressure may be required in order to properly set the Model LP Dry Valve Actuator.

The Electric Actuation Trim (see Fig. 6) is used when electric detection and releasing are desired. This trim set includes a solenoid valve 250 psi (17,2 bar) rated, two inch main drain, alarm test supply pressure gauge, push rod chamber supply connections, push rod chamber pressure gauge, and the Model B-SS Hydraulic Manual Emergency Station. Detailed description of electrical operation can be found in Bulletins 700 and 722.

The Model B-SS Hydraulic Manual Emergency Station is a standard item in all trim sets. However, the Model A Hydraulic Manual Emergency Station, described in Bulletin 506, is also available as an option.

All Model DDX-SS Deluge Valves are listed by Underwriters Laboratories, Inc, and certified by UL for Canada (cULus) and certified by Factory Mutual Approvals, only when used with the valve manufacturer's trim sets.

WET PILOT LINE DELUGE TRIM

RECOMMENDED INSTALLATION LOCATION FOR A FIRE DEPT. CONNECTION (FDC) IS ABOVE THE MODEL DDX DELUGE VALVE.

AVAILABLE TRIM CONFIGURATIONS:

- 1) INDIVIDUAL PARTS (MODEL DDX DELUGE VALVE SOLD SEPARATELY)
- 2) SEGMENTALLY ASSEMBLED (MODEL DDX DELUGE VALVE SOLD SEPARATELY)
- 3) FULLY ASSEMBLED TO MODEL DDX DELUGE VALVE

ALL STEEL COMPONENTS OF THE TRIM ASSEMBLIES ARE STAINLESS STEEL

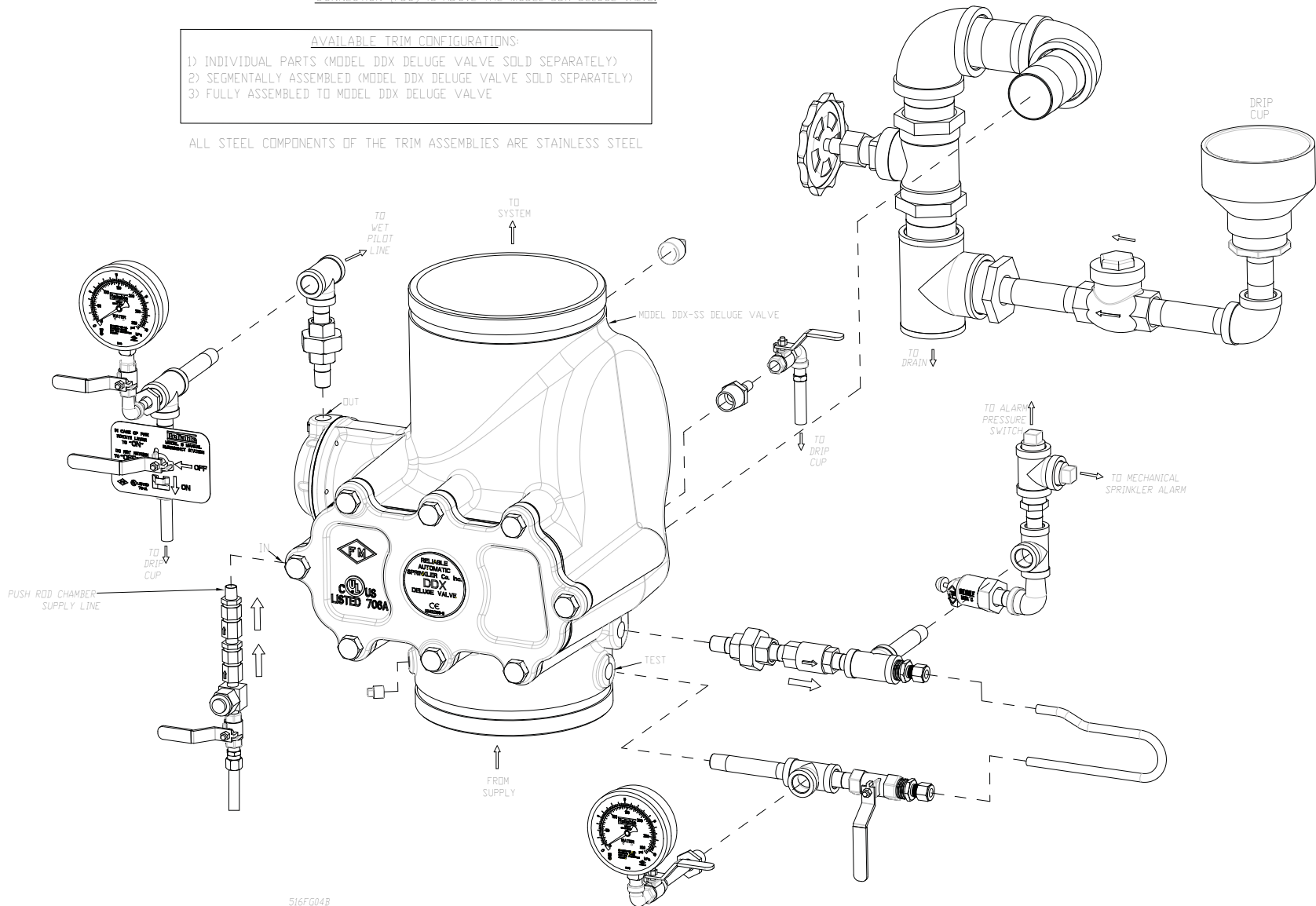

516FG04B

Fig. 4

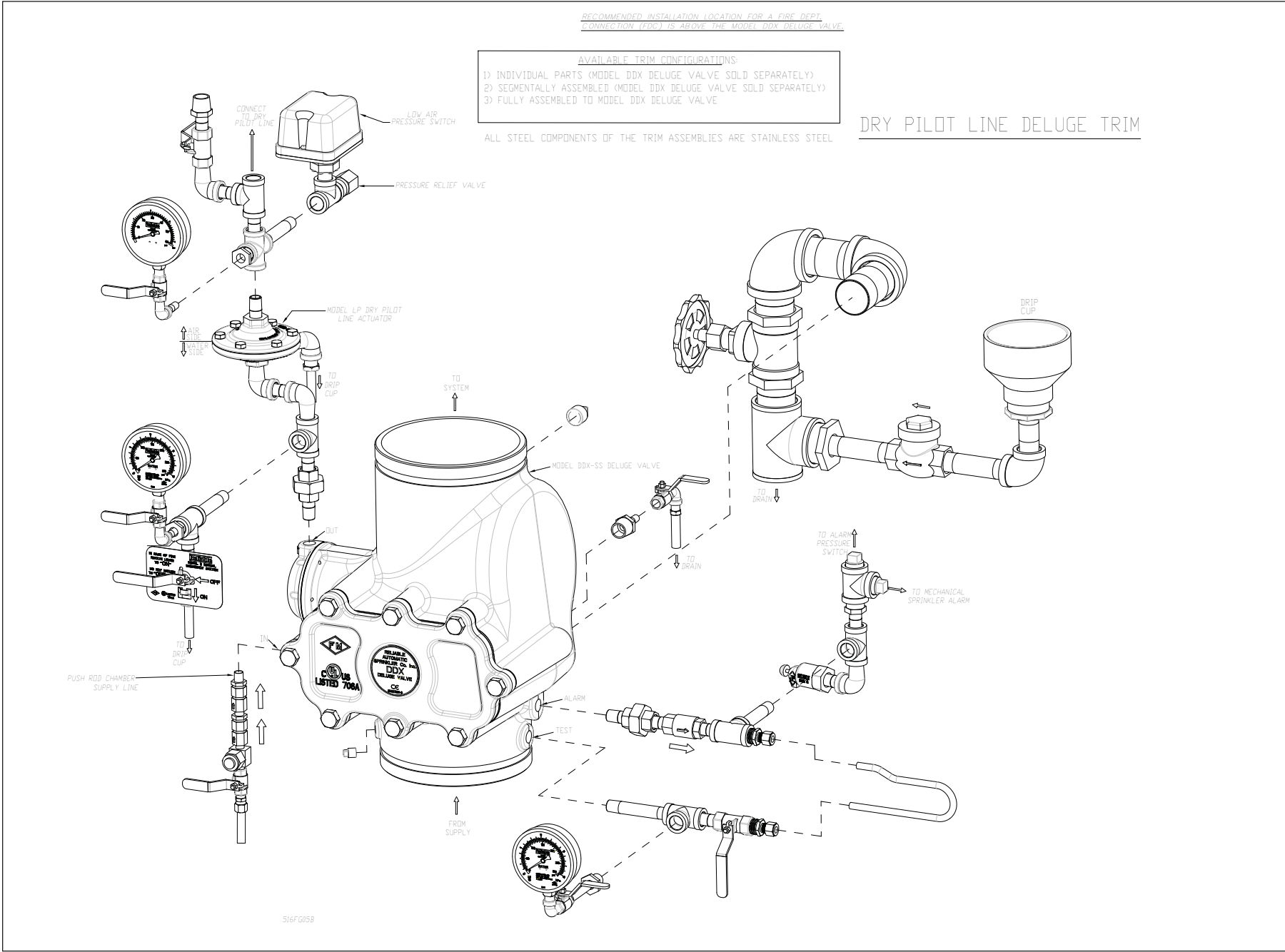

Fig. 5

RECOMMENDED INSTALLATION LOCATION FOR A FIRE DEPT. CONNECTION (FDC) IS ABOVE THE MODEL DDX DELUGE VALVE.

AVAILABLE TRIM CONFIGURATIONS:

- 1) INDIVIDUAL PARTS (MODEL DDX DELUGE VALVE SOLD SEPARATELY)
- 2) SEGMENTALLY ASSEMBLED (MODEL DDX DELUGE VALVE SOLD SEPARATELY)
- 3) FULLY ASSEMBLED TO MODEL DDX DELUGE VALVE

ALL STEEL COMPONENTS OF THE TRIM ASSEMBLIES ARE STAINLESS STEEL

ELECTRIC ACTUATION DELUGE TRIM

6.

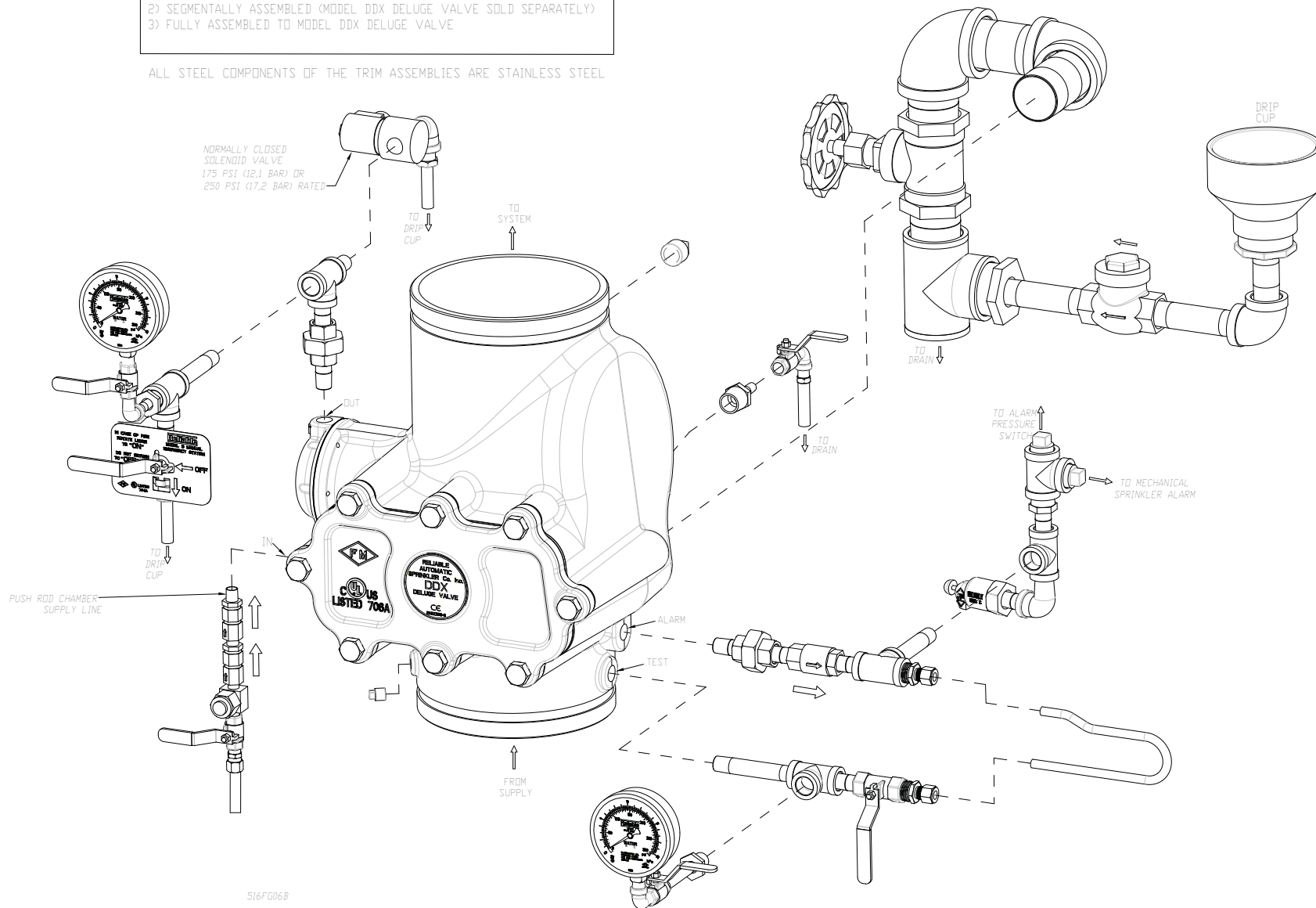

Fig. 6

Ordering Information

Specify:

- **Valve Model & Size** — 4" (100 mm) Grv/Grv (P/N 6103040037), 4" (100 mm) Flg/Flg Class 150 (P/N 6103040039), 4" (100 mm) Flg/Flg Class 300 (P/N 6103040040), 6" (150 mm) Grv/Grv (P/N 6103060037), 6" (150 mm) Flg/Flg Class 150 (P/N 6103060039), 6" (150 mm) Flg/Flg Class 300 (P/N 6103060040), 8" (200 mm) Grv/Grv (P/N 6103080002), 8" (200 mm) Flg/Flg Class 150 (P/N 6103080005), 8" (200 mm) Flg/Flg Class 300 (P/N 6103080006).
- **Trim** — Wet Pilot Trim, Dry Pilot Trim, or Electric Actuation Trim. Each trim set is available in individual parts, in time-saving, segmentally assembled kit forms, or fully assembled to the Model DDX-SS Deluge Valve without a control valve. All trims are available in 304 stainless steel or 316 stainless steel version. The Electric Actuation trim includes a 250 psi (17,2 bar) rated solenoid valve.

Wet Pilot Line Deluge

| Size | 304 Trim Configurations | Trim Part Numbers |
|-------------|---|-------------------|
| 4" | Fully Assembled to Grv/Grv DDX-SS Valve w/o Control Valve | 6505041201 |
| | Fully Assembled to Flg/Flg Class 150 DDX-SS Valve w/o Control Valve | 6505041202 |
| | Fully Assembled to Flg/Flg Class 300 DDX-SS Valve w/o Control Valve | 6505041203 |
| 6" | Fully Assembled to Grv/Grv DDX-SS Valve w/o Control Valve | 6505061201 |
| | Fully Assembled to Flg/Flg Class 150 DDX-SS Valve w/o Control Valve | 6505061202 |
| | Fully Assembled to Flg/Flg Class 300 DDX-SS Valve w/o Control Valve | 6505061203 |
| 8" | Fully Assembled to Grv/Grv DDX-SS Valve w/o Control Valve | 6505081201 |
| | Fully Assembled to Flg/Flg Class 150 DDX-SS Valve w/o Control Valve | 6505081202 |
| | Fully Assembled to Flg/Flg Class 300 DDX-SS Valve w/o Control Valve | 6505081203 |
| 4", 6" & 8" | Segmentally Assembled (DDX Valve Sold Separately) | 6503001025 |
| | Individual Parts (DDX Valve Sold Separately) | 6503001024 |
| Size | 316 Trim Configurations | Trim Part Numbers |
| 4" | Fully Assembled to Grv/Grv DDX-SS Valve w/o Control Valve | 6505042201 |
| | Fully Assembled to Flg/Flg Class 150 DDX-SS Valve w/o Control Valve | 6505042202 |
| | Fully Assembled to Flg/Flg Class 300 DDX-SS Valve w/o Control Valve | 6505042203 |
| 6" | Fully Assembled to Grv/Grv DDX-SS Valve w/o Control Valve | 6505062201 |
| | Fully Assembled to Flg/Flg Class 150 DDX-SS Valve w/o Control Valve | 6505062202 |
| | Fully Assembled to Flg/Flg Class 300 DDX-SS Valve w/o Control Valve | 6505062203 |
| 8" | Fully Assembled to Grv/Grv DDX-SS Valve w/o Control Valve | 6505082201 |
| | Fully Assembled to Flg/Flg Class 150 DDX-SS Valve w/o Control Valve | 6505082202 |
| | Fully Assembled to Flg/Flg Class 300 DDX-SS Valve w/o Control Valve | 6505082203 |
| 4", 6" & 8" | Segmentally Assembled (DDX Valve Sold Separately) | 6503001027 |
| | Individual Parts (DDX Valve Sold Separately) | 6503001026 |

Dry Pilot Line Deluge

| | Size | 304 Trim Configurations | Trim Part Numbers |
|---|------------------------------------|---|---|
| UL/FM Approved Pressure Switch | 4" | Fully Assembled to Grv/Grv DDX-SS Valve w/o Control Valve | 6505041206 |
| | | Fully Assembled to Fig/Fig Class 150 DDX-SS Valve w/o Control Valve | 6505041207 |
| | | Fully Assembled to Fig/Fig Class 300 DDX-SS Valve w/o Control Valve | 6505041208 |
| | 6" | Fully Assembled to Grv/Grv DDX-SS Valve w/o Control Valve | 6505061206 |
| | | Fully Assembled to Fig/Fig Class 150 DDX-SS Valve w/o Control Valve | 6505061207 |
| | | Fully Assembled to Fig/Fig Class 300 DDX-SS Valve w/o Control Valve | 6505061208 |
| | 8" | Fully Assembled to Grv/Grv DDX-SS Valve w/o Control Valve | 6505081206 |
| | | Fully Assembled to Fig/Fig Class 150 DDX-SS Valve w/o Control Valve | 6505081207 |
| | | Fully Assembled to Fig/Fig Class 300 DDX-SS Valve w/o Control Valve | 6505081208 |
| | 4", 6" & 8" | Segmentally Assembled (DDX Valve Sold Separately) | 6503001132 |
| | | Individual Parts (DDX Valve Sold Separately) | 6503001131 |
| | ULC Approved Pressure Switch | 4" | Fully Assembled to Grv/Grv DDX-SS Valve w/o Control Valve |
| Fully Assembled to Fig/Fig Class 150 DDX-SS Valve w/o Control Valve | | | 6505041210 |
| Fully Assembled to Fig/Fig Class 300 DDX-SS Valve w/o Control Valve | | | 6505041211 |
| 6" | | Fully Assembled to Grv/Grv DDX-SS Valve w/o Control Valve | 6505061209 |
| | | Fully Assembled to Fig/Fig Class 150 DDX-SS Valve w/o Control Valve | 6505061210 |
| | | Fully Assembled to Fig/Fig Class 300 DDX-SS Valve w/o Control Valve | 6505061211 |
| 8" | | Fully Assembled to Grv/Grv DDX-SS Valve w/o Control Valve | 6505081209 |
| | | Fully Assembled to Fig/Fig Class 150 DDX-SS Valve w/o Control Valve | 6505081210 |
| | | Fully Assembled to Fig/Fig Class 300 DDX-SS Valve w/o Control Valve | 6505081211 |
| 4", 6" & 8" | | Segmentally Assembled (DDX Valve Sold Separately) | 6503001134 |
| | | Individual Parts (DDX Valve Sold Separately) | 6503001133 |
| | | Size | 316 Trim Configurations |
| UL/FM Approved Pressure Switch | 4" | Fully Assembled to Grv/Grv DDX-SS Valve w/o Control Valve | 6505042206 |
| | | Fully Assembled to Fig/Fig Class 150 DDX-SS Valve w/o Control Valve | 6505042207 |
| | | Fully Assembled to Fig/Fig Class 300 DDX-SS Valve w/o Control Valve | 6505042208 |
| | 6" | Fully Assembled to Grv/Grv DDX-SS Valve w/o Control Valve | 6505062206 |
| | | Fully Assembled to Fig/Fig Class 150 DDX-SS Valve w/o Control Valve | 6505062207 |
| | | Fully Assembled to Fig/Fig Class 300 DDX-SS Valve w/o Control Valve | 6505062208 |
| | 8" | Fully Assembled to Grv/Grv DDX-SS Valve w/o Control Valve | 6505082206 |
| | | Fully Assembled to Fig/Fig Class 150 DDX-SS Valve w/o Control Valve | 6505082207 |
| | | Fully Assembled to Fig/Fig Class 300 DDX-SS Valve w/o Control Valve | 6505082208 |
| | 4", 6" & 8" | Segmentally Assembled (DDX Valve Sold Separately) | 6503001136 |
| | | Individual Parts (DDX Valve Sold Separately) | 6503001135 |
| | ULC Approved Pressure Switch | 4" | Fully Assembled to Grv/Grv DDX-SS Valve w/o Control Valve |
| Fully Assembled to Fig/Fig Class 150 DDX-SS Valve w/o Control Valve | | | 6505042210 |
| Fully Assembled to Fig/Fig Class 300 DDX-SS Valve w/o Control Valve | | | 6505042211 |
| 6" | | Fully Assembled to Grv/Grv DDX-SS Valve w/o Control Valve | 6505062209 |
| | | Fully Assembled to Fig/Fig Class 150 DDX-SS Valve w/o Control Valve | 6505062210 |
| | | Fully Assembled to Fig/Fig Class 300 DDX-SS Valve w/o Control Valve | 6505062211 |
| 8" | | Fully Assembled to Grv/Grv DDX-SS Valve w/o Control Valve | 6505082209 |
| | | Fully Assembled to Fig/Fig Class 150 DDX-SS Valve w/o Control Valve | 6505082215 |
| | | Fully Assembled to Fig/Fig Class 300 DDX-SS Valve w/o Control Valve | 6505082216 |
| 4", 6" & 8" | | Segmentally Assembled (DDX Valve Sold Separately) | 6503001138 |
| | | Individual Parts (DDX Valve Sold Separately) | 6503001137 |

Electric Actuation Deluge (Explosion Proof Solenoid Available Upon Request)

| Size | 304 Trim Configurations | Trim Part Numbers |
|-------------|---|-------------------|
| 4" | Fully Assembled to Grv/Grv DDX-SS Valve w/o Control Valve | 6505041212 |
| | Fully Assembled to Fig/Fig Class 150 DDX-SS Valve w/o Control Valve | 6505041213 |
| | Fully Assembled to Fig/Fig Class 300 DDX-SS Valve w/o Control Valve | 6505041214 |
| 6" | Fully Assembled to Grv/Grv DDX-SS Valve w/o Control Valve | 6505061212 |
| | Fully Assembled to Fig/Fig Class 150 DDX-SS Valve w/o Control Valve | 6505061213 |
| | Fully Assembled to Fig/Fig Class 300 DDX-SS Valve w/o Control Valve | 6505061214 |
| 8" | Fully Assembled to Grv/Grv DDX-SS Valve w/o Control Valve | 6505081212 |
| | Fully Assembled to Fig/Fig Class 150 DDX-SS Valve w/o Control Valve | 6505081213 |
| | Fully Assembled to Fig/Fig Class 300 DDX-SS Valve w/o Control Valve | 6505081214 |
| 4", 6" & 8" | Segmentally Assembled (DDX-SS Valve Sold Separately) | 6503001530 |
| | Individual Parts (DDX-SS Valve Sold Separately) | 6503001529 |
| Size | 316 Trim Configurations | Trim Part Numbers |
| 4" | Fully Assembled to Grv/Grv DDX-SS Valve w/o Control Valve | 6505042212 |
| | Fully Assembled to Fig/Fig Class 150 DDX-SS Valve w/o Control Valve | 6505042213 |
| | Fully Assembled to Fig/Fig Class 300 DDX-SS Valve w/o Control Valve | 6505042214 |
| 6" | Fully Assembled to Grv/Grv DDX-SS Valve w/o Control Valve | 6505062212 |
| | Fully Assembled to Fig/Fig Class 150 DDX-SS Valve w/o Control Valve | 6505062213 |
| | Fully Assembled to Fig/Fig Class 300 DDX-SS Valve w/o Control Valve | 6505062214 |
| 8" | Fully Assembled to Grv/Grv DDX-SS Valve w/o Control Valve | 6505082212 |
| | Fully Assembled to Fig/Fig Class 150 DDX-SS Valve w/o Control Valve | 6505082213 |
| | Fully Assembled to Fig/Fig Class 300 DDX-SS Valve w/o Control Valve | 6505082214 |
| 4", 6" & 8" | Segmentally Assembled (DDX-SS Valve Sold Separately) | 6503001536 |
| | Individual Parts (DDX-SS Valve Sold Separately) | 6503001535 |

Note: For metric installations, a 2" NPT x R2. ISO 7/1 x Close Nipple (Reliable P/N 98543401) is sold separately as an adapter for the single drain outlet of the trims.

- **Additional equipment** — Air compressors, electric detection, actuation equipment, and mechanical sprinkler alarms must be ordered separately. These devices are described in Bulletin 700.

| Nominal Pipe Size | Installation Dimensions in Inches (mm) | | | | | | | | | | | | | | | | |
|-------------------|--|-------------|--------------|--------------|--------------|--------------|--------------|--------------|-------------|--------------|------------|-------------|-------------|-------------|--------------|--------------|--------------|
| | A | B | C | D* | D** | E | F | G | H | J | K | L | M | N | P | Q | R |
| 4" | 10½ (267) | 7¾ (197) | 10 (254) | 14 (356) | 16 (406) | 29¾ (756) | 23¾ (603) | 31 (787) | 7¾ (197) | 15¾ (400) | 7 (178) | 8½ (216) | 17 (432) | 8½ (216) | 10½ (267) | 11½ (292) | 13¾ (349) |
| 6" | 10½ (267) | 8½ (216) | 10¾ (273) | 16 (406) | 18 (457) | 31½ (800) | 25½ (648) | 32¾ (832) | 8¼ (210) | 16¼ (413) | 7 (178) | 8½ (216) | 18 (457) | 8½ (216) | 10½ (267) | 11¾ (298) | 14¼ (362) |
| 8" | 10½ (267) | 9¼ (235) | 11½ (292) | 19¾ (492) | 21¼ (540) | 31¾ (807) | 25¾ (654) | 33 (838) | 9 (229) | 17 (432) | 7 (178) | 8½ (216) | 17 (432) | 8 (203) | 10 (254) | 12¼ (311) | 15 (381) |

D* is for groove-groove versions
D** is for flange-flange versions

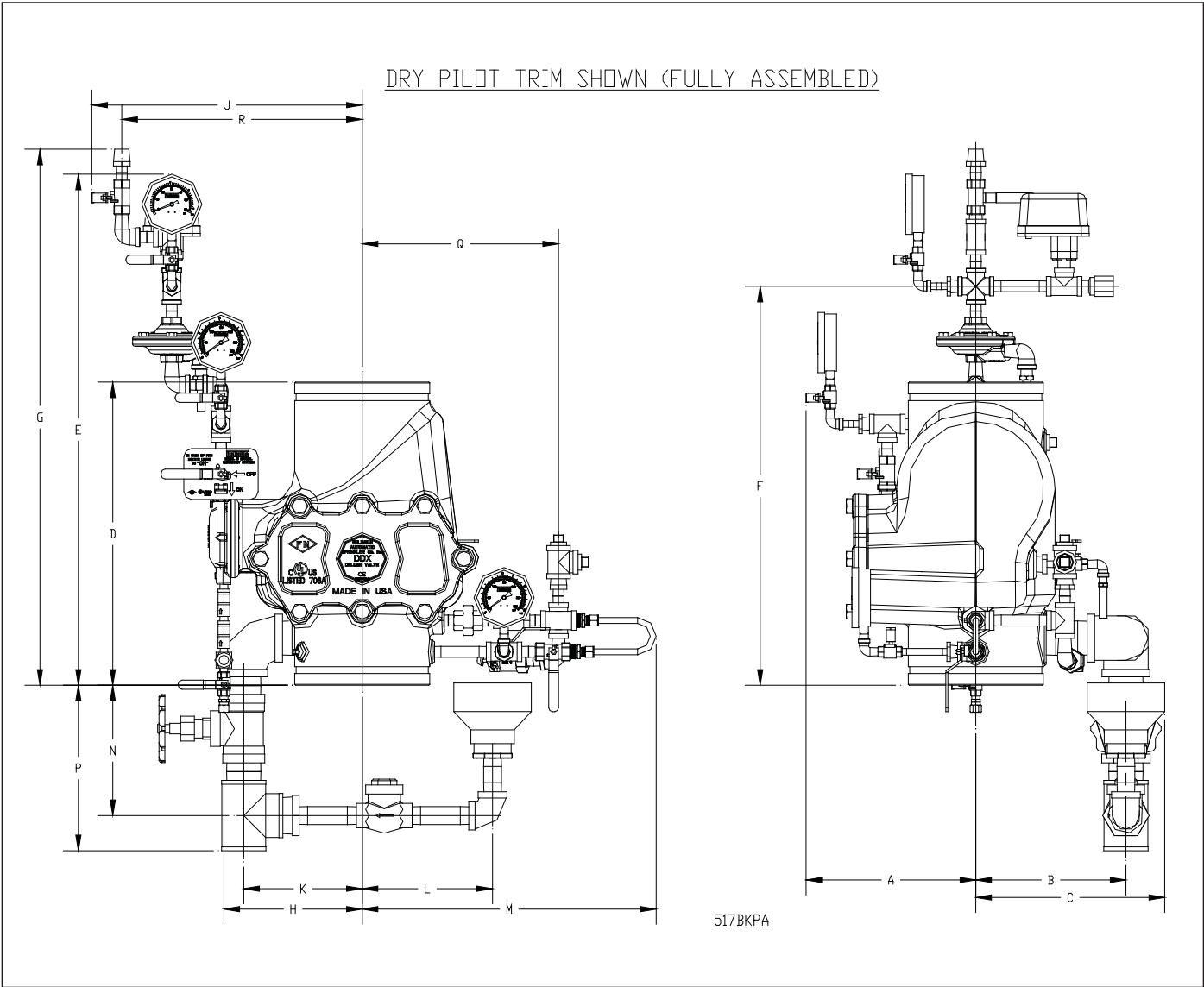

The equipment presented in this bulletin is to be installed in accordance with the latest published Standards of the National Fire Protection Association, Factory Mutual Research Corporation, or other similar organizations and also with the provisions of governmental codes or ordinances whenever applicable. Products manufactured and distributed by Reliable have been protecting life and property for over 90 years, and are installed and serviced by the most highly qualified and reputable sprinkler contractors located throughout the United States, Canada and foreign countries.

Manufactured by



The Reliable Automatic Sprinkler Co., Inc.

(800) 431-1588 Sales Offices
(800) 848-6051 Sales Fax
(914) 829-2042 Corporate Offices
www.reliablesprinkler.com Internet Address



Revision lines indicate updated or new data.

EG. Printed in U.S.A. 11/12 P/N 9999970375