

Reliable®

Model EX Low Pressure Dry Pipe Valve System

2" (DN50), 2½" (DN65), 3" (DN80),
76 mm, 4" (DN100), 6" (DN150),
165 mm & 8" (DN200)

Features

1. Differential latching clapper-type, lightweight, dependable construction.
2. Low Air Pressurized System, 8 psi -to- 28 psi (0.6 bar -to- 1.9 bar) Max
3. Reset externally. Cover removal is not required.
4. No priming water requirement
5. Hydrostatic testing with the clapper in the closed position
6. No riser check valve required
7. Valve latches in open position. No pressure-operated relief valve is required.
8. Nitrogen pressurized system optional
9. Drain valve to drain potential standing water column.
10. Grooved inlet and outlet.
11. Pressure rating of 250 psi (17.2 bar) or 300 psi (20.7 bar) [(4" (100mm), 6" (150mm) & 165mm only)].

Note: For retrofit applications where an existing pneumatic supply is available. The Reliable Model EX Dry Valve can be operated with 40 psi (2.8 bar) maximum air or nitrogen pressure. The higher pressure may result in a delay in valve operation and longer water delivery time when compared to the lower (design) pressures of the valve.

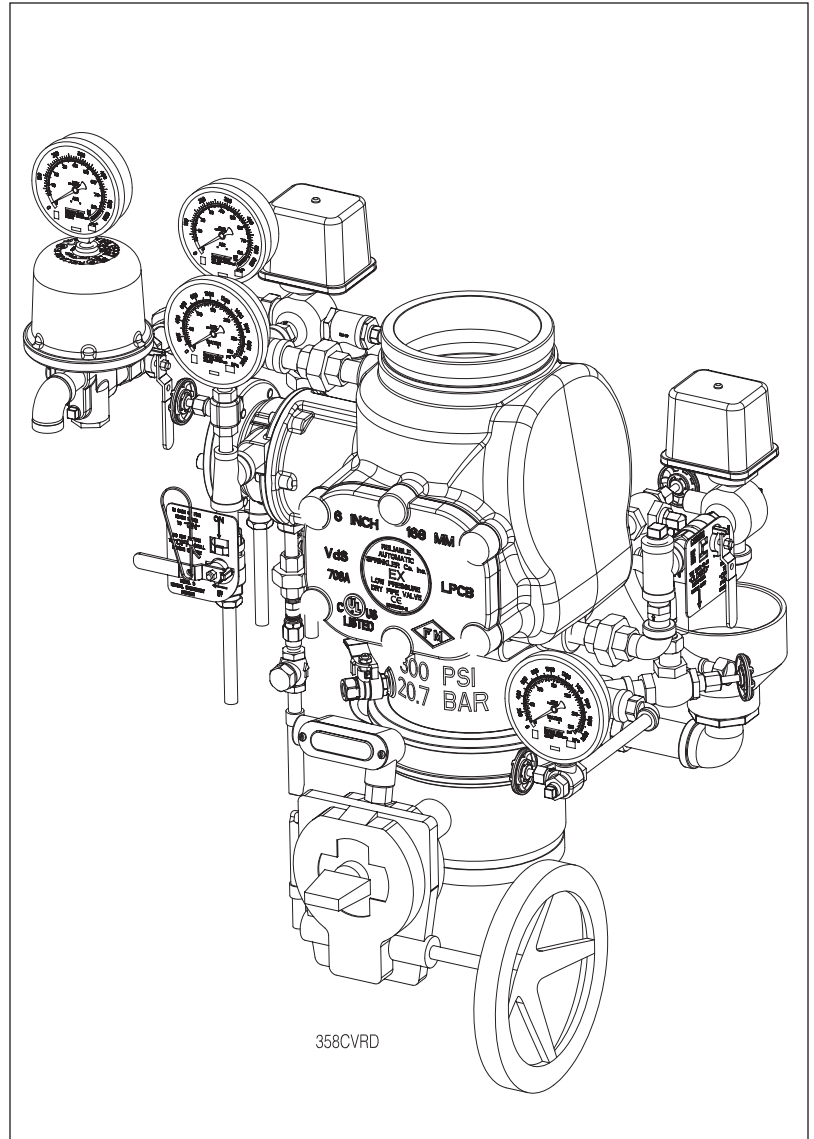

Listings & Approvals

(Only when used with Reliable's Trim Sets.)

1. Listed by Underwriters Laboratories, Inc. and UL certified for Canada (cULus).
2. Certified by Factory Mutual Approvals (FM).
3. Loss Prevention Certification Board (LPCB)
4. VdS Schadenverhütung GmbH (VdS) (DN50, DN65, DN80, DN100, DN150, and DN200 sizes only).
5. EN Certificates (CE) per EN 12259-3:2000 + A1:2001 + A2:2005
 - DN50: 0786-CPR-40300
 - DN65: 0786-CPR-40301
 - DN80: 0786-CPR-40302
 - DN100: 0786-CPR-40303
 - DN150: 0786-CPR-40304
 - DN200: 0786-CPR-40305

**SECTION VIEW OF MODEL EX DRY VALVE
WITH CLAPPER IN "OPEN", "CLOSED" AND
"LATCHED" POSITIONS**

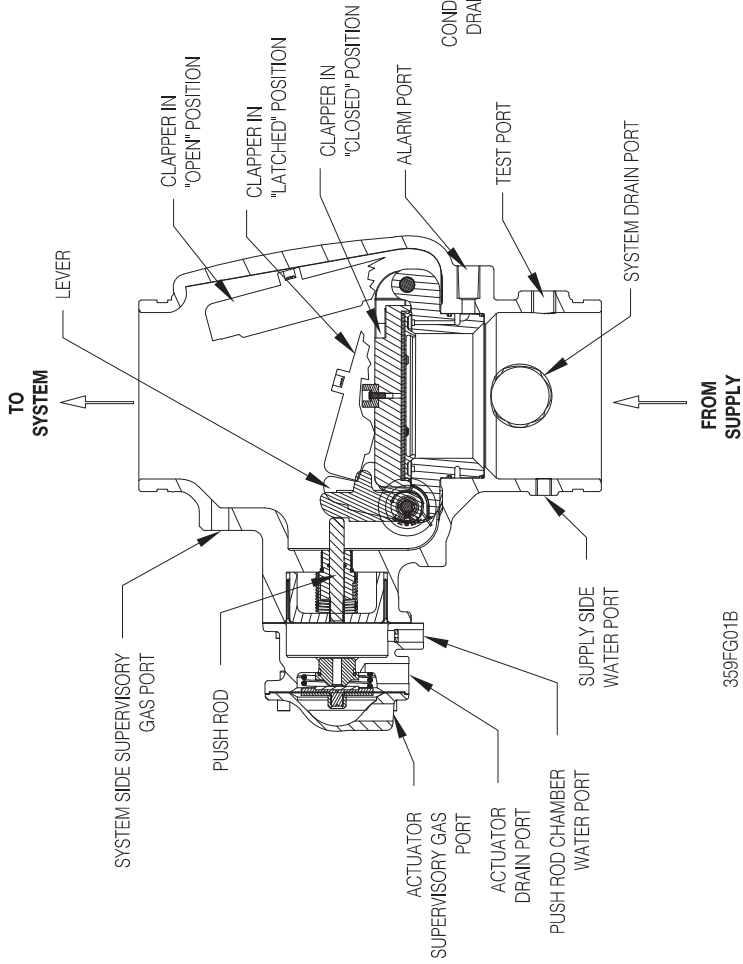

359FG01B

**REAR VIEW OF
MODEL EX DRY VALVE**

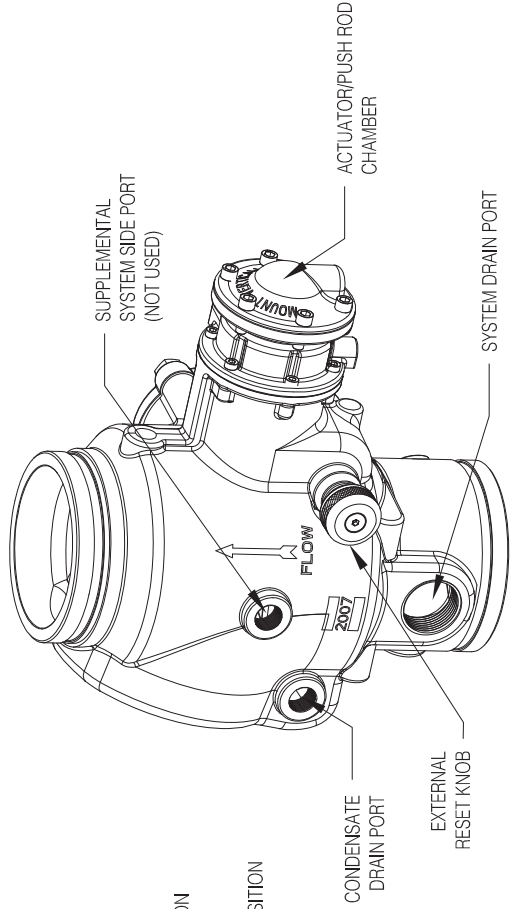

PUSH INWARD AND ROTATE EXTERNAL RESET KNOB CLOCKWISE TO RESET CLAPPER.
DO SO ONLY WHEN PUSH ROD CHAMBER IS UNPRESSURIZED (0 PSIG).

Fig. 1

General

The Reliable Model EX Low Pressure Dry Pipe Valve is a hydraulically operated, differential latching clapper-type valve (see Fig 1.) designed for use as a primary control valve in a dry pipe valve system. The trim set used with the Model EX Low Pressure Dry Pipe Valve allows the system's air or nitrogen pressure requirement to be considerably less than the available water supply pressure (See Table A, page 7). The following benefits are a direct result of the ability to use lower air pressure:

1. In refrigerated area systems, lower air pressure decreases the possibility of ice plugs, which could impede or prevent the flow of water to sprinkler heads in the event of fire.
2. Lower air pressure (volume) will enable smaller capacity, lower cost dehydration equipment when it is required.
3. Lower air or nitrogen pressure can reduce water delivery time when the system actuates, and in some cases, may eliminate the need for an accelerator.
4. Low pressure requirements make the use of dry nitrogen gas, instead of air, practical even on larger systems. Resulting benefits include a lower-than-air dew point, which minimizes ice plugging of system lines, and enhances "user friendliness" during installation and operation.
5. System maintenance is simplified since priming water is not required and the Dry Pipe Valve can be reset externally without cover removal. This is accomplished by pushing in and turning the external reset knob at the rear of the Dry Pipe Valve (see Fig.1). This feature provides a significant system-restoration time advantage.

The Model EX Low Pressure Dry Pipe Valve's trim set (see Fig.2) provides all of the necessary equipment for connections to the pushrod chamber's inlet and outlet ports, the 1¼" (30mm) or 2" (50mm) main drain, alarm devices, air supply, water supply and required pressure gauges. This trim set is available in individual parts, in time-saving, segmentally assembled kit forms, or fully assembled to the Model EX Low Pressure Dry Pipe Valve (with or without a control valve).

All the sizes of the Model EX Low Pressure Dry Pipe Valve trim sets may be equipped with the optional Reliable Model B1 Accelerator, trim kit P/N 6516000003, (see Figs. 2 & 3). This device acts as an exhauster which will hasten the operation of the Model EX Low Pressure Dry Valve and minimize the water delivery time for the entire system.

System Operation

The Reliable Model EX Low Pressure Dry Pipe Valve is shown in both closed and open positions in Fig. 1. In the closed position, the supply pressure acts on the underside of the clapper and also on the push rod through the push rod chamber's inlet restriction. The resultant force due to the supply pressure acting on the push rod is multiplied by the mechanical advantage of the lever and is more than sufficient to hold the clapper closed against normal supply pressure surges.

When a sprinkler operates, there will be a loss of air or nitrogen pressure in the sprinkler system's piping which will cause the Model EX Low Pressure Dry Valve to open. The loss of air pressure allows a releasing discharge of water from the pushrod chamber. Since the pressure cannot be replenished through the inlet restriction as rapidly as it is vented, the push rod chamber pressure falls instantaneously. When the push rod chamber pressure approaches approximately one-third of the supply pressure, the upward force of the supply pressure acting beneath the clapper overcomes the lever-applied force thereby opening the clapper.

Once the clapper has opened, the lever acts as a latch, preventing the clapper from returning to the closed position. Water from the supply flows through the Dry Pipe Valve into the system piping. Water also flows through the Dry Pipe Valve's alarm outlet to the alarm devices.

After system shutdown, resetting the Model EX Low Pressure Dry Pipe Valve is quite simple. Doing so only requires pushing in and turning the reset knob at the rear of the valve (see Fig. 1). The external reset feature of the Model EX Low Pressure Dry Pipe Valve provides a means for simple, economical system testing, which is one essential facet of a good maintenance program. The external reset feature does not, however, eliminate another important facet of good maintenance, namely, periodic cleaning and inspection of the internal valve parts.

In the event that water builds up inside the valve due to condensate from the air supply system or water left inside from valve system testing, a drain is available for venting. After closing the main supply valve, a small valve over the drain cup can be opened slightly until the water inside the valve body and the main pipe column has drained.

The Model B Manual Emergency Station is also included in the Model EX Low Pressure Dry Pipe Valve trim set. It consists of an aluminum nameplate mechanically attached to a ball valve. The valve handle in its OFF position is guarded against accidental turning to the ON position (and system discharge) by a nylon cable tie provided with each trim kit. The cable tie is inserted after the system has been restored for operation. The nylon cable tie is designed to allow, in case of an emergency, forceful turning of the valve handle to the ON position. As an alternative to the Model B Hydraulic Manual Emergency Station, the Model A Hydraulic Manual Emergency Pull Box (see Reliable Bulletin 506) is also available and can be provided as an option.

Whenever ambient temperature conditions are high, the water temperature in the Model EX Low Pressure Dry Pipe Valve's pushrod chamber could possibly increase, thereby increasing the pressure in the chamber to values exceeding the rated pressure of the system. In an indoor installation where standard room temperatures are exceeded, a pressure relief kit may be needed. Pressure relief kit, P/N 6503050001, can be installed into the pushrod chamber's releasing line to limit the pressure to 250 psi (17.2 bar).

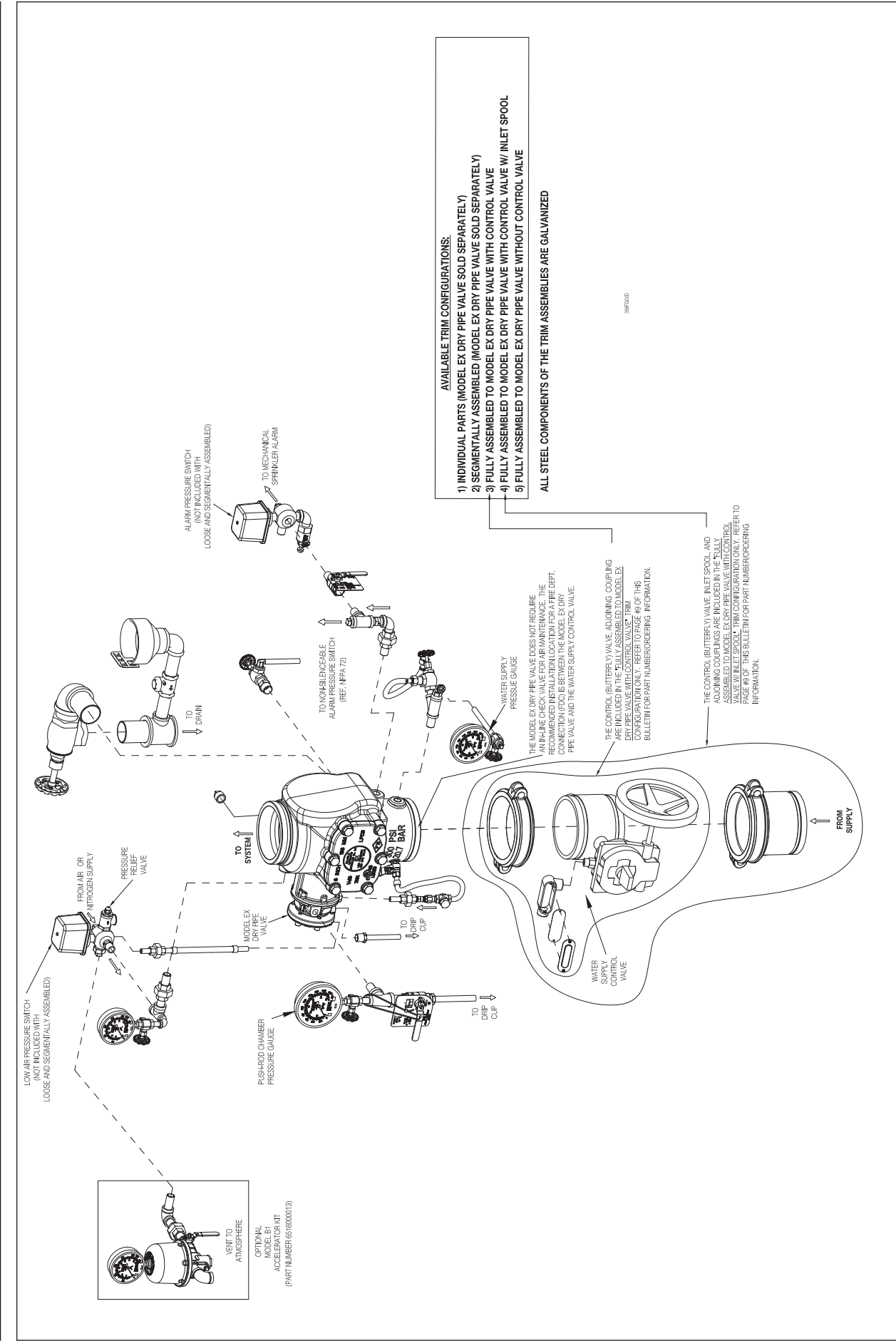

Fig. 2

Hydrostatic Testing of EX Valves and EX Systems

As required by NFPA 13, fire sprinkler systems with working pressures up to and including 150 psi are to be hydrostatically tested at a water pressure of 200 psi and maintain that pressure without loss for two hours. Fire sprinkler systems with working pressures above 150 psi are required to be hydrostatically tested at 50 psi above the system working pressure and maintain that pressure without loss for two hours. In addition to the hydrostatic tests described above, dry pipe systems require an additional low pressure air test.

In some cases, hydrostatic testing (in accordance with the NFPA 13 requirements noted above) will result in pressures that exceed the working Pressure of the valve and trim kit for the two-hour test period. The valve and applicable trim kit have been tested, approved and listed under these conditions and as such, hydrostatic testing in accordance with NFPA 13 is acceptable. In addition, the clapper can remain in the closed position and the trim kit need not be isolated, as each has been designed to withstand hydrostatic testing as required by NFPA 13.

Hydrostatically testing the valve and trim to pressures higher than their rating is limited to the hydrostatic test as referenced by NFPA13. It does not address the occurrence(s) of a “water hammer” effect, which can indeed damage the valve. A “water hammer” in the water supply piping of the valve can create pressures in excess of the rated pressure and should be avoided by all necessary means. This condition may be created from improper fire pump settings, underground construction work, or an improper venting of trapped air in the water supply piping.

Technical Data

Reliable Model EX Low Pressure Dry Pipe Valves, with associated trim, sizes 2” (50mm), 2½” (65mm), 3” (80mm), 76mm & 8” (200mm) are rated for use at a minimum water supply pressure of 20 psi (1.4 bar) and a maximum water supply pressure of 250 psi (17.2 bar), sizes 4” (100mm), 6” (150mm) & 165mm are rated for use at a minimum water supply pressure of 20 psi (1.4 bar) and a maximum water supply pressure of 300 psi (20.7 bar). Water supplied to the inlet of the valve and to the pushrod chamber must be maintained between 40°F (4°C) and 140°F (60°C).

The following list of technical bulletins pertains to valves and devices that may be used in this Dry Pipe Valve system:

Model EX Dry Pipe Valve	Reliable 358/359
Mechanical Sprinkler Alarm	Reliable 612/613
Pressure Maintenance Device	Reliable 254
Nitrogen Regulating Device	Reliable 254
Model B1 Accelerator Trim Kit	Reliable 323
Hydraulic Emergency Station (Model A)	Reliable 506
Low Air Pressure Alarm Switch (Potter)	5401564
Waterflow Pressure Alarm Switch (Potter)	5400928

Model EX Low Pressure Dry Pipe Valve Description

1. Valve & System - Pressure Rated to 250 psi (17.2 bar) for 2” (50mm), 2½”(65mm), 76mm and 8” (200mm) and 300 psi (20.7 bar) for 4” (100mm), 165mm & 6” (150mm)
2. Factory tested to a hydrostatic pressure of (Valve only) 500 psi (34.5 bar) for 2” (50mm), 2½” (65mm), 76mm and 8” (200mm), 600 psi (41.4 bar) for 4” (100mm), 165mm & 6” (150mm).
3. End and trim connections:
 - ANSI/AWWA C606 dimensions:

Nominal Pipe Size	Outlet Diameter	Groove Diameter	Groove Width	Outlet Face to Groove
2” (50 mm)	2.375” (60mm)	2.250” (57mm)	11/32” (9.0mm)	5/8” (16mm)
2½” (65 mm)	2.875” (73mm)	2.720” (69mm)	11/32” (9.0mm)	5/8” (16mm)
76 mm	3.000” (76mm)	2.845” (72mm)	11/32” (9.0mm)	5/8” (16mm)
3” (80 mm)	3.500” (89mm)	3.344” (85mm)	11/32” (9.0mm)	5/8” (16mm)
4” (100 mm)	4.500” (114mm)	4.334” (110mm)	3/8” (9.5mm)	5/8” (16mm)
165 mm	6.500” (165mm)	6.330” (161mm)	3/8” (9.5mm)	5/8” (16mm)
6” (150 mm)	6.625” (168mm)	6.455” (164mm)	3/8” (9.5mm)	5/8” (16mm)
8” (200 mm)	8.625” (219mm)	8.441” (214mm)	7/16” (11mm)	3/4” (19mm)

- Flange dimensions:

Flange Type	Nominal Pipe Size	Bolt Circle Diameter	Bolt Hole Diameter	Flange Outside Diameter	Flange Thickness	Number of Bolts
ASME B16.5 Class 150	4” (100mm)	7½” (191mm)	¾” (19mm)	9” (229mm)	15/16” (24mm)	8
ISO 7005-2 PN16	4” (100mm)	7½” (180mm)	¾” (19mm)	9” (229mm)	15/16” (24mm)	8
ASME B16.5 Class 150	6” (150mm)	9½” (241mm)	7/8” (22mm)	11” (279mm)	15/16” (24mm)	8
ISO 7005-2 PN16	6” (150mm)	9½” (240mm)	29/32” (23mm)	11” (279mm)	15/16” (24mm)	8
ASME B16.5 Class 150	8” (200mm)	11¼” (298mm)	7/8” (22mm)	13½” (343mm)	1” (25.4mm)	8
ISO 7005-2 PN16	8” (200mm)	11½” (295mm)	29/32” (23mm)	13½” (343mm)	1” (25.4mm)	12

- Threaded openings Per ANSI B 2.1

RELIABLE MODEL B1 ACCELERATOR KIT (P/N 6516000003)

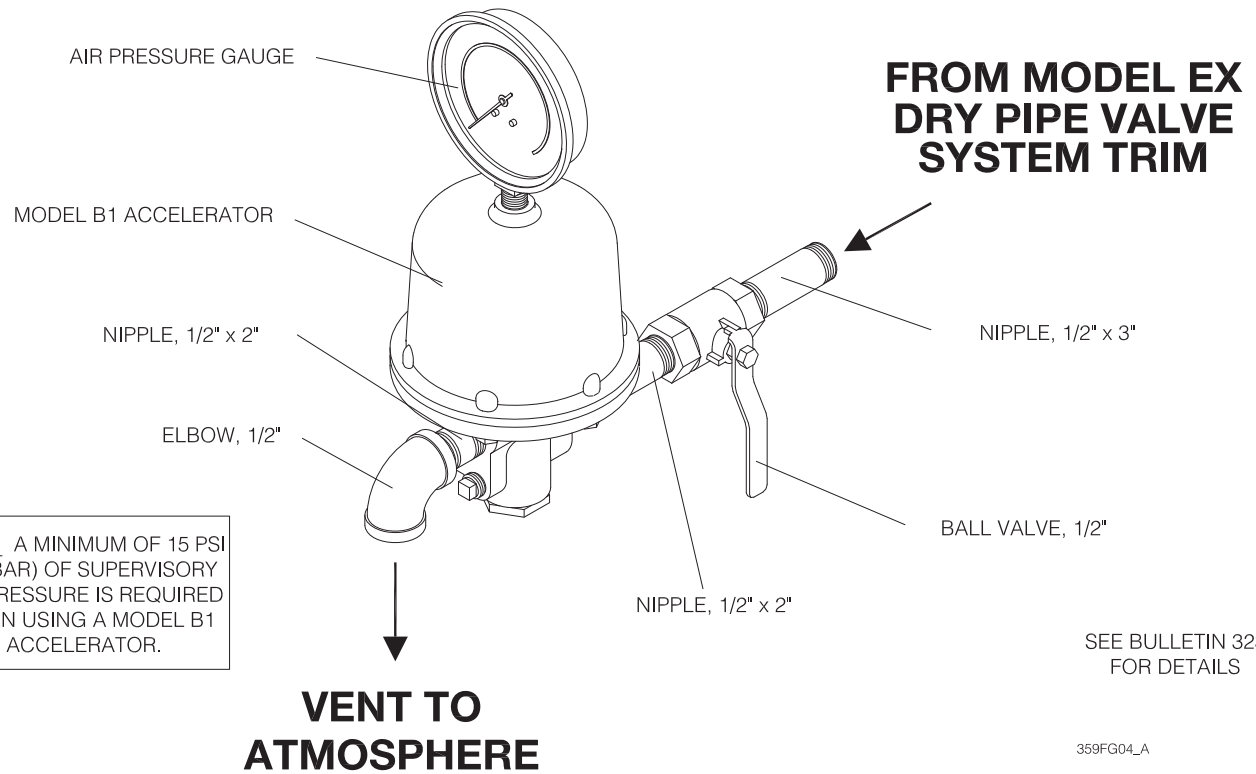

Fig. 3

MODEL B HYDRAULIC MANUAL EMERGENCY STATION

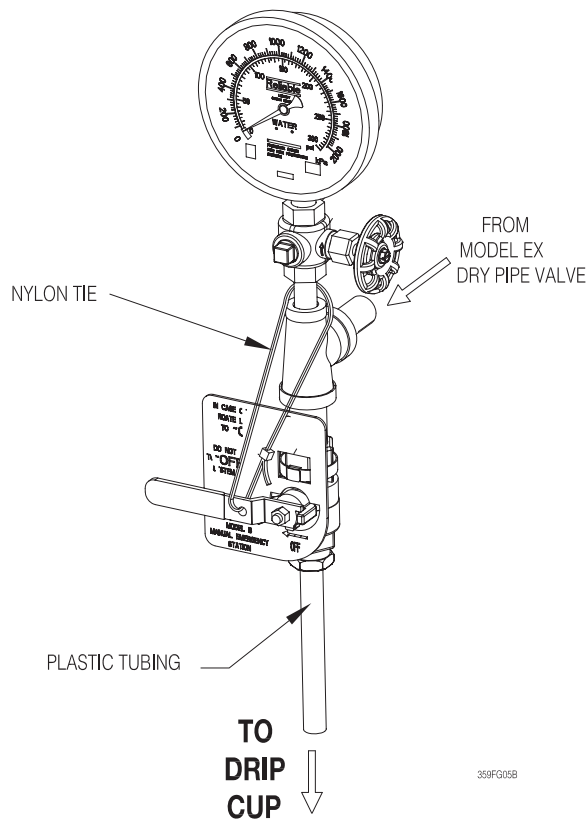

Fig. 4

4. Valve Exterior's Color:

Valve Size	Color
2" (50 mm)	Black or Red
2½" (65 mm)	Black or Red
76 mm	Red
3" (80 mm)	Black or Red
4" (100 mm)	Black or Red
165 mm	Red
6" (150 mm)	Black or Red
8" (200 mm)	Black or Red

5. Face to face dimensions:

Valve Size	End Connection:	End to End:	
2" (50mm), 2½" (65mm), 76mm & 3" (80mm)	Groove/ Groove	12½" (318mm)	
	4" (100mm)	Groove/ Groove	14" (356mm)
		Flange/ Groove	16" (406mm)
6" (150mm) & 165mm	Flange/ Flange	16" (406mm)	
	8" (200mm)	Groove/ Groove	16" (406mm)
		Flange/ Groove	19" (483mm)
8" (200mm)	Flange/ Flange	19" (483mm)	
	Groove/ Groove	19¾" (492mm)	
	Flange/ Flange	21¼" (540mm)	

6. Valve Shipping Weight:

Valve Size:	End Connection:	Weight:	
2" (50mm), 2½" (65mm), 76mm & 3" (80mm)	Groove/ Groove	34 lbs (15 kg)	
	4" (100mm)	Groove/ Groove	64 lbs (29 kg)
		Flange/ Groove	79 lbs (36 kg)
6" (150mm) & 165mm	Flange/ Flange	92 lbs (42 kg)	
	8" (200mm)	Groove/ Groove	95 lbs (43 kg)
		Flange/ Groove	122 lbs (56 kg)
8" (200mm)	Flange/ Flange	138 lbs (69 kg)	
	Groove/ Groove	148 lbs (67 kg)	
	Flange/ Flange	197 lbs (90 kg)	

7. Trim Shipping Weight:

Valve Size:	Weight:
2" (50mm), 2½" (65mm), 76mm & 3" (80mm)	30 lbs (13.6 kg)
4" (100mm), 6" (150mm), 165mm & 8" (200mm)	34 lbs (15.5 kg)

8. Friction loss (Expressed in equivalent length of Schedule 40 pipe, based on Hazen & Williams formula.

Valve Size:	Equivalent Length:		Cv
	C = 120	C = 100	
2" (50mm)	4.4 ft (1,3 m)	3.1 ft (1,0 m)	101
2½" (65mm)	6.0 ft (1,8 m)	4.3 ft (1,3 m)	236
76mm	7.7 ft (2,3 m)	5.5 ft (1,7 m)	241
3" (80mm)	12.6 ft (3,8 m)	9.0 ft (2,7 m)	254
4" (100mm)	14 ft (4,3 m)	10 ft (3,0 m)	469
165mm	29.4 ft (9,0 m)	20.9 ft (6,4 m)	886
6" (150mm)	29.4 ft (9,0 m)	20.9 ft (6,4 m)	886
8" (200mm)	53.5 ft (16,3 m)	38.1 ft (11,6 m)	1516

9. Installation position: Vertical

System Air or Nitrogen Pressure Requirements

The system trim includes gauges to read the pneumatic and water pressures of Model EX Dry Valve. Table A specifies the air or nitrogen pressure level to be applied to the Model EX Dry Pipe Valve. Optional Reliable Model A-2 Pressure Maintenance Device (see Reliable Bulletins 254) automatically provides a safeguard against pressure leaks in the sprinkler piping, and properly restricts the flow of makeup air. When the optional Model B1 Accelerator is used, a Model A-2 Pressure Maintenance Device and a tank-mounted air compressor are required. Also, when a Model B1 Accelerator is used, to expedite water-delivery time, the pneumatic pressure must not be less than 15 psi (1.0 bar).

Whenever multiple dry systems are installed at the same location, each dry system is to have its own Model A-2 Pressure Maintenance Device installed for individual maintenance of air pressure (Refer to the 2007 Edition of NFPA 13, section 7.2.6.5.3).

Table A (For the fastest water transit time, use no more than the "Best Performance Max" pneumatic pressure)

Water Pressure psi (bar)	Pneumatic Pressure to be Pumped into Sprinkler System psi (bar)	
Maximum	Not Less Than	Best Performance Max
20 (1.4)	8 (0.6)	10 (0.7)
30 (2.1)	10 (0.7)	14 (1.0)
50 (3.4)	12 (0.8)	16 (1.1)
75 (5.2)	13 (0.9)	17 (1.2)
100 (6.9)	15 (1.0)	19 (1.3)
125 (8.6)	16 (1.1)	20 (1.4)
150 (10.3)	17 (1.2)	21 (1.4)
175 (12.1)	18 (1.2)	22 (1.5)
200 (13.8)	19 (1.3)	23 (1.6)
225 (15.5)	21 (1.4)	25 (1.7)
250 (17.2)	22 (1.5)	26 (1.8)
275 (19.0)	23 (1.6)	27 (1.9)
300 (20.7)	24 (1.7)	28 (1.9)

Note: During system set-up, a higher pneumatic pressure may be required in order to properly set the Model EX Dry Valve.

Nitrogen used in refrigerated area systems minimizes a possibility of ice build-up and blockage inside the system piping that could inhibit proper system operation. The calculated nitrogen supply in lbs (kg) to pressurize various system capacities to 10 psi (0.7 bar) at different freezer temperatures is as follows:

System Capacity Gal. (L)	Freezer Temperature, °F (°C)					Approx. Fill Time (min*)
	20 (-6.7)	0 (-18)	-20 (-29)	-40 (-40)	-60 (-51)	
250 (946)	1.90 (0.86)	1.90 (0.86)	2.00 (0.91)	2.10 (0.95)	2.20 (1.00)	1
500 (1893)	3.64 (1.65)	2.80 (1.27)	4.00 (1.81)	4.20 (1.91)	4.40 (2.00)	2
750 (2839)	5.50 (2.49)	5.70 (2.59)	6.00 (2.72)	6.30 (2.86)	6.60 (2.99)	3
1000 (3785)	7.30 (3.31)	7.60 (3.45)	8.00 (3.63)	8.33 (3.78)	8.80 (3.99)	4

Note: (1 bar = 100 kPa)

Consult Reliable Bulletin 357 for more detailed information.

* When filled with the Reliable Model A-2 Pressure Maintenance Device having the bypass valve open.

Patents

U.S. Patent Pending for a Dry Pipe Valve Arrangement

Ordering Information

Specify:

- Valve Model, Size & End Connection –

Valve Part Numbers			
Valve Size & End Connection	Flange Type	Color	Reliable Part Number
2" (50mm) Grv/Grv	N/A	Black	6101021010
		Red	6101021015
2½" (65mm) Grv/Grv	N/A	Black	6101025010
		Red	6101025015
3" (80mm) Grv/Grv	N/A	Black	6101031010
		Red	6101031015
76mm Grv/Grv	N/A	Red	6101051015
4" (100mm) Grv/Grv	N/A	Black	6101041010
		Red	6101041015
4" (100mm) Flg/Grv	ASME Class 150	Black	6101041020
	ASME Class 150	Red	6101041025
	ISO PN16	Red	6101041045
4" (100mm) Flg/Flg	ASME Class 150	Black	6101041030
	ASME Class 150	Red	6101041035
	ISO PN16	Red	6101041055
6" (168mm) Grv/Grv	N/A	Black	6101061010
		Red	6101061015
6" (168mm) Flg/Grv	ASME Class 150	Black	6101061020
	ASME Class 150	Red	6101061025
	ISO PN16	Red	6101061045
6" (168mm) Flg/Flg	ASME Class 150	Black	6101061030
	ASME Class 150	Red	6101061035
	ISO PN16	Red	6101061055
165mm Grv/Grv	N/A	Red	6101065015
165mm Flg/Grv	ASME Class 150	Red	6101065025
	ISO PN16	Red	6101065045
8" (200mm) Grv/Grv	N/A	Black	6101081010
		Red	6101081015
8" (200mm) Flg/Flg	ASME Class 150	Black	6101081030
	ASME Class 150	Red	6101081035
	ISO PN16	Red	6101081055

- **Trim** — The trim set is available in individual parts, in time-saving segmentally assembled kit forms, or fully assembled to the Model EX Low Pressure Dry Pipe Valve (with or without a control valve).

TRIM PART NUMBERS:

2" (50MM), 2-1/2" (65MM), 3" (80MM) & 76MM:
 INDIVIDUAL TRIM COMPONENTS (ASSEMBLY REQUIRED, EX VALVE NOT INCLUDED):6501030001
 SEGMENTALLY ASSEMBLED TRIM (EX VALVE NOT INCLUDED):6501030002
 4" (100MM), 6" (168MM), 165MM & 8" (200MM):
 INDIVIDUAL TRIM COMPONENTS (ASSEMBLY REQUIRED, EX VALVE NOT INCLUDED):6501060001
 SEGMENTALLY ASSEMBLED TRIM (EX VALVE NOT INCLUDED):6501060002

FOR FULLY ASSEMBLED TO MODEL EX VALVE SEE THE PART NUMBER SCHEME BELOW:

PART NUMBER SCHEME:

MISC OPTIONS:
 0: BLACK VALVE
 A: RED VALVE
 B: RED VALVE WITH DOMESTIC TRIM
 C: CHINESE MARKINGS ON VALVE
 D: BLACK VALVE WITH DOMESTIC TRIM

VALVE SIZE:
 1: 2" (50MM)
 2: 2-1/2" (65MM)
 3: 3" (80MM)
 4: 4" (100MM)
 5: 76MM
 6: 6" (168MM)
 7: 165MM
 8: 8" (200MM)

PRESSURE SWITCHES:
 1: POTTER WITH UL/ULC/FM APPROVALS
 2: SYSTEM SENSOR WITH ULC APPROVALS
 3: SYSTEM SENSOR WITH UL/FM APPROVALS

EXAMPLE P/N: 6506061010

CONTROL VALVE/ACCELERATOR:
 0: WITHOUT CONTROL VALVE, WITHOUT ACCELERATOR
 1: WITH CONTROL VALVE, WITHOUT ACCELERATOR
 2: WITHOUT CONTROL VALVE, WITH ACCELERATOR
 3: WITH CONTROL VALVE, WITH ACCELERATOR
 4: WITH CONTROL VALVE, WITH INLET SPOOL
 5: WITH CONTROL VALVE, WITH INLET SPOOL AND ACCELERATOR
NOTE: 76MM & 165MM NOT AVAILABLE WITH CONTROL VALVE.
4" (100MM), 6" (168MM) & 165MM WITH FLANGED INLET AND
FLANGED OUTLET OR FLANGED INLET AND FLANGED OUTLET
NOT AVAILABLE WITH CONTROL VALVE. 8" (200MM) WITH
FLANGED INLET AND FLANGED OUTLET NOT AVAILABLE WITH
CONTROL VALVE

END CONNECTION:
 1: GROOVED INLET, GROOVED OUTLET
 2: CLASS 150 FLANGED INLET, GROOVED OUTLET
 3: CLASS 150 FLANGED INLET, CLASS 150 FLANGED OUTLET
 4: PN16 FLANGED INLET, GROOVED OUTLET
 5: PN16 FLANGED INLET, PN16 FLANGED OUTLET
NOTE: 2" (50MM), 2-1/2" (65MM), 3" (80MM) & 76MM NOT AVAILABLE
WITH FLANGED INLET AND FLANGED OUTLET OR FLANGED
INLET AND FLANGED OUTLET, 8" (200MM) NOT AVAILABLE
WITH FLANGED INLET AND GROOVED OUTLET

THE EXAMPLE IS A BLACK 6" (168MM) VALVE WITH POTTER PRESSURE SWITCHES, WITHOUT A CONTROL VALVE, WITHOUT AN ACCELERATOR AND HAS A GROOVED INLET AND GROOVED OUTLET

359FG11B

Fig. 5

• **Additional equipment**

Component Part	Mfgr.	Description	Technical Bulletin
Water Supply Control Valve	Select	OS&Y	-
		Butterfly,	-
Tamper Switch (Optional) for OS&Y Valve	B	Model OS&Y2	Potter 5400928
Tamper Switch (Optional) for Butterfly Valve		Model P1BV2	Potter 5400928
Dry Pipe Valve	A	Model EX	Reliable 358/359
Dry Pipe Valve System	A	Refer to Parts in this Bulletin	Reliable 358/359
Waterflow Alarm Pressure Switch	B	Model PS10-2 (DPDT cULus, FM)	Potter 5400928
		Model PS10-2 (DPDT VdS)	
Low Air Alarm Pressure Switch	B	Model PS25-2 (DPDT cULus, FM)	Potter 5401564
		Model PS25-2 (DPDT VdS)	
Mechanical Alarm (Optional)	A	Model C	Reliable 612/613
Manual Emergency Station	A	Model A Hydraulic (Pilot Line) Type	Reliable 506
Sprinklers	A	Closed Type	Reliable 110, 117, 131, 136, etc.
Air Compressor*	C	Per NFPA 13	F-30
Pressure Maintenance Device	A	Model A-2	Reliable 254
Accelerator Kit*	A	Model B1	Reliable 323
Nitrogen Regulating Device	A	Regulator with Optional Low Air Pressure Switch	Reliable 254

*If the optional Model B1 Accelerator is used, a tank-mounted air compressor and an A-2 pressure maintenance device must be provided. Additionally the use of a tank-mounted air compressor helps to eliminate on/off compressor cycling that may occur as a result of small leakage in the air line between the pressure maintenance device and the 1/2" check valve, as well as due to ambient temperature changes in the system piping.

System Equipment Manufacturers

- (A) Reliable Automatic Sprinkler Co., Inc.
- (B) Potter
- (C) Gast Manufacturing Corp.

Nominal Pipe Size	Installation Dimensions in Inches (mm)																			
	A	B	C	D*	D**	D***	D****	D*****	E	F	G	H	I	J	K	L	M	N	P	Q
2" (50 mm)	8½ (216)	7 (178)	7½ (191)	12½ (318)	15¾ (400)	21¼ (540)	N/A	N/A	10¼ (260)	20¾ (527)	12½ (318)	4½ (114)	8¾ (222)	6¾ (171)	7¼ (184)	6¾ (171)	16 (406)	6 (152)	11 (279)	9¾ (248)
2½" (65 mm), 3" (80 mm) & 76 mm	8½ (216)	7 (178)	7½ (191)	12½ (318)	16½ (419)	22 (559)	N/A	N/A	10¼ (260)	20¾ (527)	12½ (318)	4½ (114)	8¾ (222)	6¾ (171)	7¼ (184)	6¾ (171)	16 (406)	6 (152)	11 (279)	9¾ (248)
4" (100 mm)	8½ (216)	7½ (191)	7½ (191)	14 (356)	18¾ (476)	24¼ (616)	16 (406)	16 (406)	11½ (292)	22 (559)	15¼ (387)	5½ (140)	9¾ (248)	7¾ (197)	8 (203)	10½ (267)	17½ (445)	6 (152)	11 (279)	11¾ (298)
6" (150 mm) & 165 mm	8½ (216)	8 (203)	7½ (191)	16 (406)	21¼ (540)	26¾ (679)	19 (483)	19 (483)	13¼ (337)	23¾ (603)	16 (406)	5½ (140)	10¼ (260)	8 (203)	10 (254)	11 (279)	19½ (495)	6 (152)	11 (279)	11¾ (298)
8" (200 mm)	8½ (216)	8½ (215)	7½ (191)	19¾ (492)	25¼ (641)	30¾ (781)	N/A	21¼ (540)	13½ (343)	24 (610)	16½ (419)	5½ (140)	12¼ (311)	9 (229)	7½ (191)	12¼ (311)	19¼ (489)	6 (152)	11 (279)	11¾ (298)

D* is the takeout for a Grv/Grv EX valve only.

D** is the total takeout for a Grv/Grv EX valve with a Reliable control valve or, for 2" (50 mm) valves only, Anvil control valve. Substituting a NIBCO control valve increases the total takeout to 22" (559 mm) for a 6" (150 mm) valve and reduces the total takeout to 24¾" (629 mm) for an 8" (200 mm) valve.

D*** is the total takeout for a Grv/Grv EX valve with an Inlet Spool and a Reliable control valve or, for 2" (50 mm) valves only, Anvil control valve. Substituting a NIBCO control valve increases the total takeout to 27½" (698 mm) for a 6" (150 mm) valve and reduces the total takeout to 30¼" (769 mm) for an 8" (200 mm) valve.

D**** is the takeout for a Flg/Grv EX valve only.

D***** is the takeout for a Flg/Flg EX valve only.

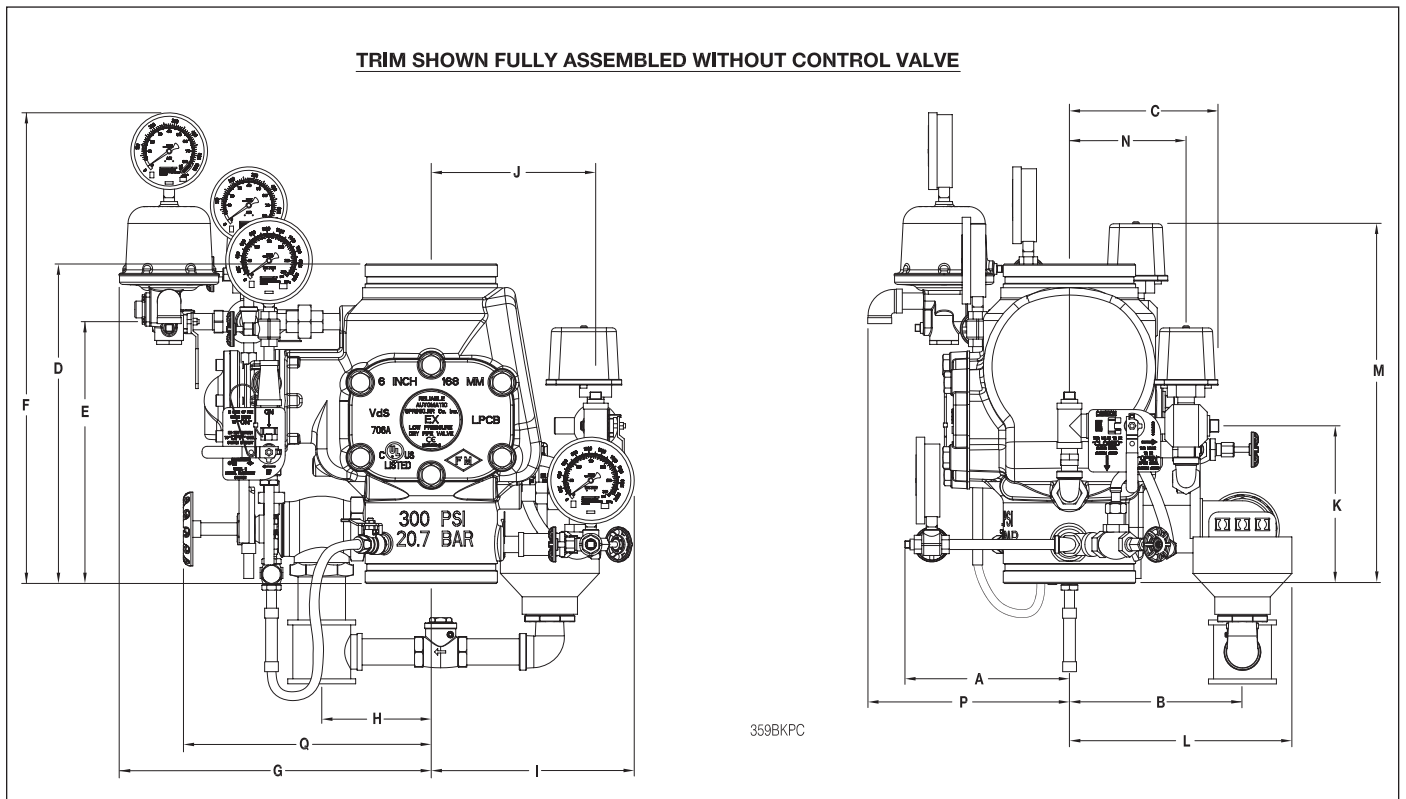

Reliable...For Complete Protection

Reliable offers a wide selection of sprinkler components. Following are some of the many precision-made Reliable products that guard life and property from fire around the clock.

- Automatic sprinklers
- Flush automatic sprinklers
- Recessed automatic sprinklers
- Concealed automatic sprinklers
- Adjustable automatic sprinklers
- Dry automatic sprinklers
- Intermediate level sprinklers
- Open sprinklers
- Spray nozzles
- Alarm valves
- Retarding chambers
- Dry pipe valves
- Accelerators for dry pipe valves
- Mechanical sprinkler alarms
- Electrical sprinkler alarm switches
- Water flow detectors
- Deluge valves
- Detector check valves
- Check valves
- Electrical system
- Sprinkler emergency cabinets
- Sprinkler wrenches
- Sprinkler escutcheons and guards
- Inspectors test connections
- Sight drains
- Ball drips and drum drips
- Control valve seals
- Air maintenance devices
- Air compressors
- Pressure gauges
- Identification signs
- Fire department connection

The equipment presented in this bulletin is to be installed in accordance with the latest published Standards of the National Fire Protection Association, Factory Mutual Research Corporation, or other similar organizations and also with the provisions of governmental codes or ordinances whenever applicable. Products manufactured and distributed by Reliable have been protecting life and property for almost 100 years.

Manufactured by

Reliable[®]

Reliable Automatic Sprinkler Co., Inc.

(800) 431-1588

(800) 848-6051

(914) 829-2042

www.reliablesprinkler.com

Sales Offices

Sales Fax

Corporate Offices

Internet Address



Recycled
Paper

Revision lines indicate updated or new data.

EG. Printed in U.S.A. 11/16 P/N 999970426