

Reliable®

Model DDX
Double Interlock
Preaction System – Type PL
 2" (50 mm), 2½" (65 mm), 3" (80 mm),
 76 mm, 4" (100 mm), 6" (150 mm),
 165 mm & 8" (200mm)

Instructions for Installation, Operation, Care and Maintenance

8 - 28 PSI (0.6 - 1.9 bar) Pneumatic Supervising
 Pressure with Pneumatic/Pneumatic Actuation
 Type PL

- Completely Mechanical Operation
- Externally Resettable Clapper
- One Main Drain

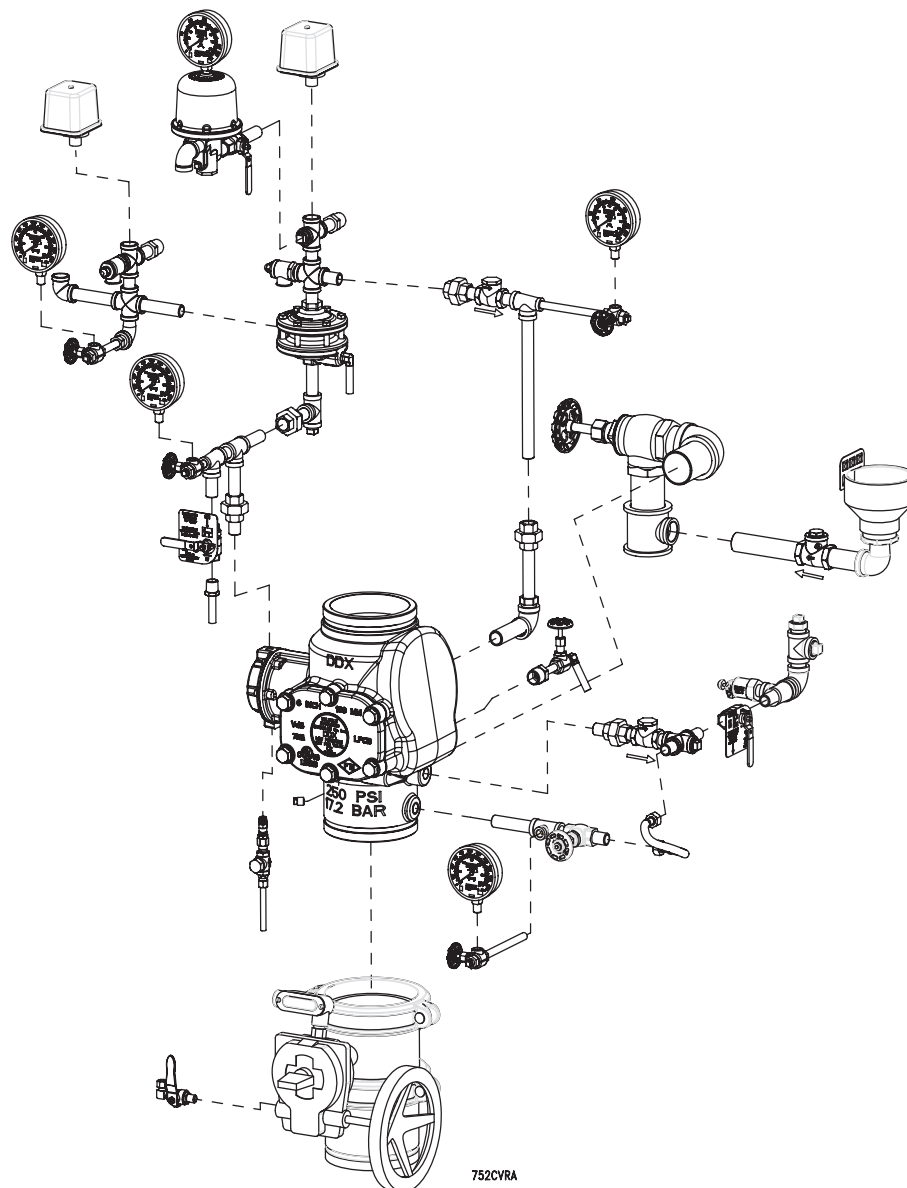

General

Type PL Double Interlock Preaction Systems are designed for water sensitive areas that require the maximum protection from inadvertent water flow into the sprinkler system piping and where power loss is common, or where electronic detection may not be desirable.

The Type PL double interlock trim package includes the Model LPDI Double Interlock Actuator as a releasing device. The sprinkler system is pressurized with air or nitrogen (see note 1 below) that keeps one chamber of the Model LPDI Double Interlock Actuator closed. A dry pilot line is pressurized with either air or nitrogen to keep the other chamber of the Model LPDI Double Interlock Actuator closed. To flow water into a Type PL Double Interlock Preaction System, two events must take place: both of the Model LPDI Double Interlock Actuator chambers must be opened. This occurs with the venting of the sprinkler system air pressure due to a sprinkler activation and the venting of the pilot line air pressure through the activation of a pilot line detector.

In the event that the system piping is ruptured, or a sprinkler head is accidentally opened, the Model LPDI Double Interlock Actuator will not open, but a low system air pressure supervisory alarm will sound. The Model DDX Deluge Valve will not be released to flow water since the air pressure in the pilot line piping has not been released. The same result would occur if a pilot line detector or the pilot line piping was damaged. The low pressure switch will activate a supervisory alarm, however again, the Model DDX Deluge Valve will not flow water due to the fact that the Model LPDI Double Interlock Actuator remains closed.

This requirement for both a loss of air pressure in the pilot line piping and the loss of system air pressure before the Model DDX Deluge Valve releases water into a preaction system assures maximum protection against inadvertent water flow before a sprinkler is open. Type PL Double Interlock Preaction Systems are primarily used to protect areas where accidental water release before a sprinkler is opened can cause ice blockage, resulting in an inoperative sprinkler system and substantial property damage. Due to the strictly mechanical means of operation, this system is ideal for areas that are prone to power failure, or where electronic detection may not be desirable.

At the heart of Reliable's Type PL Double Interlock Preaction System is the Model DDX Deluge Valve. This Deluge Valve is a hydraulically operated, straight through design, latching type valve (see Fig. 1). System maintenance is simplified since priming water is not required and the Model DDX Deluge Valve can be reset externally without cover removal. This is accomplished by pushing in and turning the external reset knob at the rear of the Deluge Valve (see Fig. 1). This feature provides a significant system restoration time advantage.

The Reliable Model DDX Type PL Double Interlock Preaction System trim set (see Fig. 3 & Fig. 4) provides all of the necessary equipment for connections to the Model DDX Deluge Valve's pushrod chamber inlet and outlet ports, a 1¼" (30 mm) main drain on 2" (50 mm), 2½" (65 mm), 76 mm and 3" (80 mm) valve sizes or a 2" (50 mm) main drain on 4" (100 mm), 165 mm, 6" (150 mm) and 8" (200 mm) valve sizes, alarm devices, air supply, water supply and required pressure gauges. This trim set is available in individual (loose) parts, in time-saving, segmented assembled kit forms or fully assembled to the Model DDX Deluge Valve (with or without a control valve).

All sizes of Type PL Double Interlock Preaction Trims may be equipped with the optional Reliable Model B1 Accelerator, trim kit P/N 6516000003, (see Figs 2, 3 & 4). This device acts as an exhaustor which will hasten the operation of the Model LPDI Double Interlock Actuator and minimize the water delivery time for the entire system.

Listings & Approvals:

(Only when used with Reliable's Trim Sets.)

1. Reliable's Type PL Double Interlock Preaction Systems 2" (50 mm), 2½" (65 mm), 76 mm and 3" (80 mm), 4" (100 mm), 165 mm, 6" (150 mm) and 8" (200 mm) are Factory Mutual Approved Refrigerated Area Sprinkler Systems for use in refrigerated rooms or buildings. Refrigerated area sprinkler systems are FM Approved as complete systems.
2. Reliable's Type PL Double Interlock Preaction Systems 2" (50 mm), 2½" (65 mm), 76 mm, 3" (80 mm), 4" (100 mm), 165 mm, 6" (150 mm) and 8" (200 mm) are Underwriters Laboratories, Inc. Listed and UL certified for Canada (cULus) in the Special System Water Control Valve-Double Interlock Type (VLJH) category.
3. The NYC acceptance number for this system is MEA 258-93-E.

The Reliable Model DDX Type PL Double Interlock Preaction System is UL Listed and FM Approved only when used with the trim components shown in Fig. 2 & 3.

Note 1: Wherever the word "air" is used in this bulletin as a reference to the pneumatic pressure source it shall also mean "air or nitrogen."

**DDX VALVE CLAPPER IN "OPEN", "CLOSED" AND
"LATCHED" POSITIONS**

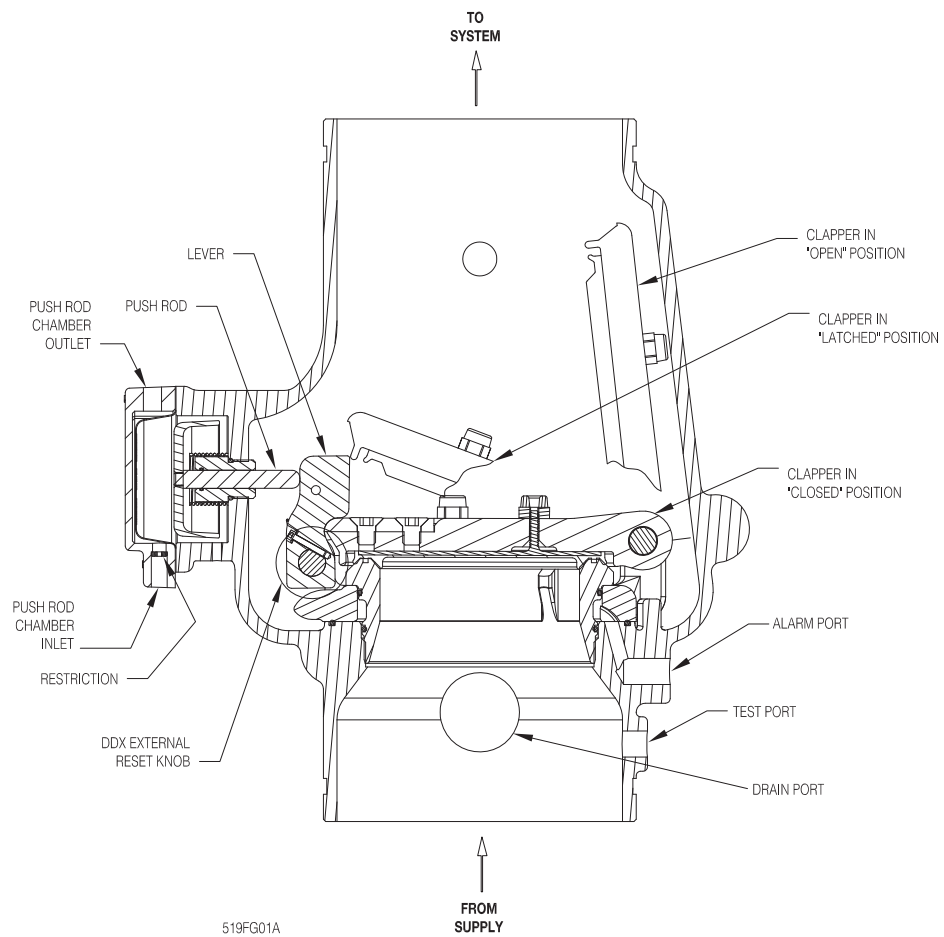

**REAR VIEW OF MODEL DDX
VALVE**

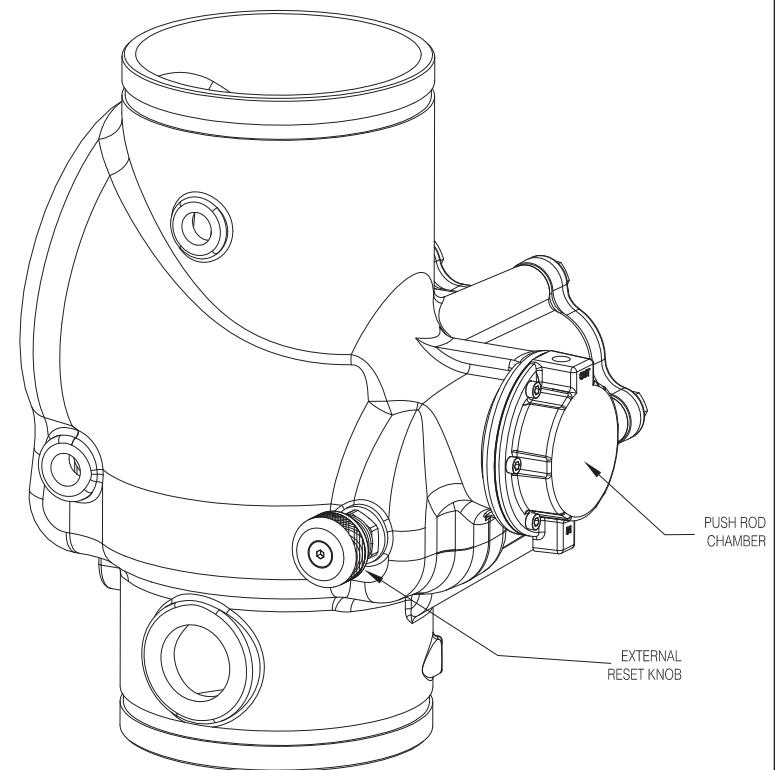

PUSH INWARD AND ROTATE KNOB CLOCKWISE TO RESET CLAPPER.
DO SO ONLY WHEN PUSH ROD CHAMBER IS VENTED.

Fig. 1

TYPE PL DOUBLE INTERLOCK

2" (50MM), 2-1/2" (65MM), 76MM, 3" (80MM)

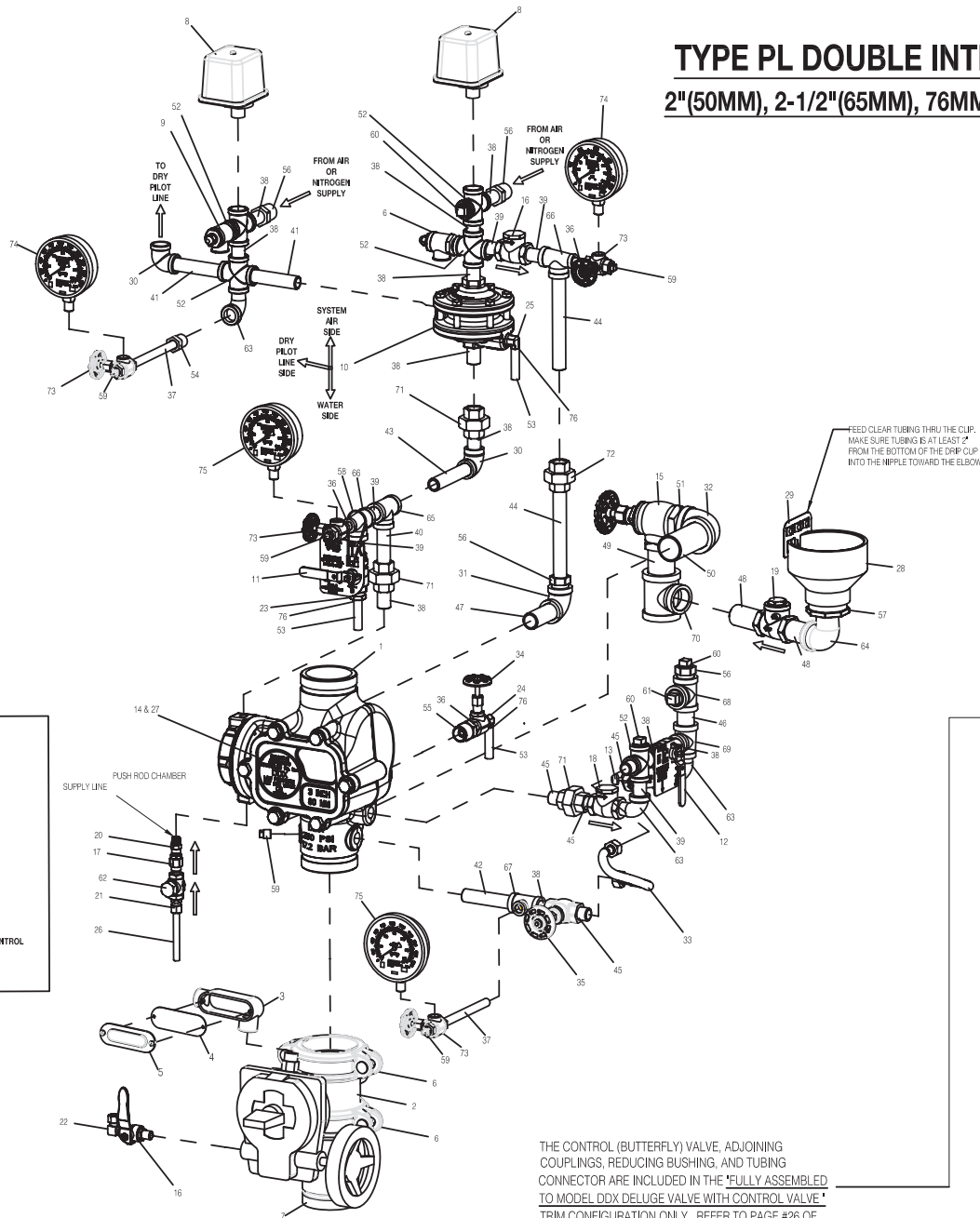

FOR RECOMMENDED INSTALLATION LOCATION FOR A FIRE DEPT. CONNECTION (FDC) REFER TO NFPA 13 APPENDIX A.8.16.1.1

AVAILABLE TRIM CONFIGURATIONS:

- INDIVIDUAL PARTS (MODEL DDX DELUGE VALVE SOLD SEPERATELY)
- SEGMENTALLY ASSEMBLED (MODEL DDX DELUGE VALVE SOLD SEPERATELY)
- FULLY ASSEMBLED TO MODEL DDX DELUGE VALVE WITHOUT CONTROL VALVE
- FULLY ASSEMBLED TO MODEL DDX DELUGE VALVE WITH CONTROL VALVE*

* FULLY ASSEMBLED TO MODEL DDX DELUGE VALVE WITH CONTROL VALVE* TRIM CONFIGURATION (NOT AVAILABLE WITH 76MM MODEL DDX VALVE)

THE CONTROL (BUTTERFLY) VALVE, ADJOINING COUPLINGS, REDUCING BUSHING, AND TUBING CONNECTOR ARE INCLUDED IN THE "FULLY ASSEMBLED TO MODEL DDX DELUGE VALVE WITH CONTROL VALVE" TRIM CONFIGURATION ONLY. REFER TO PAGE #26 OF THIS BULLETIN FOR PART NUMBER/ORDERING INFORMATION.

7537 0028

Fig. 2

Small DDX TYPE PL Trim (Refer to Fig. 2)

Item No.	Part No.			Description	QTY.
	Galvanized	Brass	Black Pipe		
1	6103022000	6103022000	6103022000	Valve Assembly, 2" (50mm) - For 2" Assembly Only	1
	6103022500	6103022500	6103022500	Valve Assembly, 2½" (65mm) - For 2½" Assembly Only	
	6103027600	6103027600	6103027600	Valve Assembly, 76mm - For 76mm Assembly Only	
	6103030000	6103030000	6103030000	Valve Assembly, 3" (80mm) - For 3" Assembly Only	
2	6990003549	6990003549	6990003549	Butterfly Valve, 2" - For 2" Assembly Only	1
	7M99002653	7M99002653	7M99002653	Butterfly Valve, 2½" - For 2½" Assembly Only	
	7M99002654	7M99002654	7M99002654	Butterfly Valve, 3" - For 3" Assembly Only	
3	98020036	98020036	98020036	Conduit Body, 1/2"	1
4	98020034	98020034	98020034	Conduit Cover Gasket, Neoprene	1
5	98020033	98020033	98020033	Conduit Body Cover	1
6	7G05080800	7G05080800	7G05080800	Rigid Coupling, 2" - For 2" Assembly Only	2
	7G05101000	7G05101000	7G05101000	Rigid Coupling, 2½" - For 2½" Assembly Only	
	7G05121200	7G05121200	7G05121200	Rigid Coupling, 3" - For 3" Assembly Only	
7	91004002	91004002	91004002	Inlet Spool, 2" - For 2" Assembly Only	1
	91004001	91004001	91004001	Inlet Spool, 2½" - For 2½" Assembly Only	
	91004003	91004003	91004003	Inlet Spool, 3" - For 3" Assembly Only	
8	6990019313	6990019313	6990019313	Potter Pressure Switch, PS25-2 (cULus/FM)	1
	6990019536	6990019536	6990019536	Potter Pressure Switch, PS25-2 (VdS)	
9	98840195	98840195	98840195	Pressure Relief Valve (33 psi)	2
10	71030020	71030020	71030020	Model DI-SS Double Interlock Actuator	1
11	78653000	78653000	78653000	Manual Emergency Station Assembly	1
12	78653004	78653004	78653004	Valve Caution Station Assembly	1
13	78653100	78653100	78653100	Ball Drip Valve, ½"	1
14	99080002	99080002	99080002	Adhesive Pad	1
15	98840106	98840106	98840106	Angle Valve, 1¼"	1
16	98840117	98840117	98840117	Ball Valve, ¼" NPTF x ¼" NPTM	1
17	98840188	98840188	98840188	Check Valve, ¼" NPTM x ¼" NPTF	1
18	98840181	98840181	98840181	Check Valve, Horizontal Swing, ½" NPT	2
19	98840145	98840145	98840145	Check Valve, Horizontal Swing, 1" NPT	1
20	98840147	98840147	98840147	Check Valve, Inline Poppet, ¼"	1
21	92056702	92056702	92056702	Compression Connector, 3/8" ID Tube x ¼" NPT	1
22	92056703	92056703	92056703	Compression Connector, Elbow 3/8" ID Tube x ¼" NPT	1
23	92056810	92056810	92056810	Connector, 3/8" ID Tube x ½" NPT	1
24	92056705	92056705	92056705	Connector, Elbow, 3/8" ID Tube x ¼" NPT	1
25	92056704	92056704	92056704	Connector, Elbow, 3/8" ID Tube x ½" NPT	1
26	96686722	96686722	96686722	Copper Tubing, 3/8" OD x 2 ft.	1

Item No.	Part No.			Description	QTY.
	Galvanized	Brass	Black Pipe		
27	94616931	94616931	94616931	Double Interlock Type PL Nameplate	1
28	98050004	98050004	98050004	Drain Cup, PVC	1
29	95306270	95306270	95306270	Drain Hose Clip	1
30	98174401	98174440	98164401	Elbow, ½"	2
31	98174402	98174441	98164400	Elbow, ¾"	1
32	98174414	98174443	98164407	Elbow, 1¼"	1
33	96920912	96920912	96920912	Flex Line, ½"	1
34	98840172	98840172	98840172	Globe Valve, ¼"	1
35	98840171	98840171	98840171	Globe Valve, ½"	1
36	98543226	98533226	98523213	Nipple ¼" x 1½"	3
37	98543217	98533217	98523217	Nipple ¼" x 6"	2
38	98543223	98533223	98523210	Nipple ½" x 1½"	12
39	98543209	98533209	98523209	Nipple ½" x 2"	5
40	98543230	98533230	98523230	Nipple ½" x 3"	1
41	98543216	98533216	98523216	Nipple ½" x 3½"	2
42	98543243	98533207	98526522	Nipple ½" x 4"	1
43	98543228	98533228	98523234	Nipple ½" x 4½"	1
44	98543211	98533211	98523239	Nipple ½" x 6½"	2
45	98543212	98533212	98523221	Nipple ½" x Close	4
46	98543232	98533232	98523242	Nipple ¾" x 2"	1
47	98543231	98533231	98523240	Nipple ¾" x 3"	1
48	98543263	98533263	98523261	Nipple 1" x 3"	2
49	98543239	98533239	98523256	Nipple 1¼" x 3"	1
50	98543250	98533264	98523264	Nipple 1¼" x 4"	1
51	98543285	98533285	98523274	Nipple 1¼" x Close	1
52	98750003	98750033	98750013	Pipe Cross, ½"	5
53	96686756	96686756	96686756	PVC Tubing, 3/8" ID x 6 ft.	1
54	98048000	98058000	98048020	Reducer Bushing, ½" x ¼"	1
55	98048025	98058025	98048011	Reducer Bushing, ¾" x ¼"	1
56	98048022	98058022	98048012	Reducer Bushing, ¾" x ½"	4
57	98048015	98048015	98048015	Reducer Bushing, 2" Spigot x 1" NPTF, PVC	1
58	89141112	89141112	89141112	Retaining Tie	9
59	98614403	98614412	98604403	Square Head Plug, ¼"	5
60	98604406	98614411	98604402	Square Head Plug, ½"	3
61	98614401	98614413	98604401	Square Head Plug, ¾"	1
62	98727607	98727607	98727607	Strainer, ¼"	1
63	98174400	98174446	98164409	Street Elbow, ½"	3
64	98174416	98174449	98174412	Street Elbow, 1"	1
65	98761651	96606915	98761603	Tee, ½"	1
66	98761649	96606916	98761604	Tee, ½" x ¼" x ½"	2
67	96606607	96606912	98761605	Tee, ½" x ½" x ¼"	1
68	96606601	96606911	98766521	Tee, ¾"	1
69	96606612	96606913	98761614	Tee, ¾" x ½" x ½"	1
70	96606603	96606917	98761621	Tee, 1¼" x ¼" x 1"	1
71	98815200	*98815300	98805200	Union, ½"	3
72	98815204	N/A	98845204	Union, ½", O-ring Seal	1
73	98840160	98840160	98840160	Valve, 3-way, ¼"	4
74	98248000	98248000	98248000	Air Pressure Gauge (0-80 psi)	2
75	98248001	98248001	98248001	Water Pressure Gauge (0-300 psi)	2
76	95306255	95306255	95306255	Hose Clamp	3

*4 qty. of p/h 98815300 for brass trim only.

TYPE PL DOUBLE INTERLOCK

4" (100MM), 165MM, 6" (150MM) & 8" (200MM)

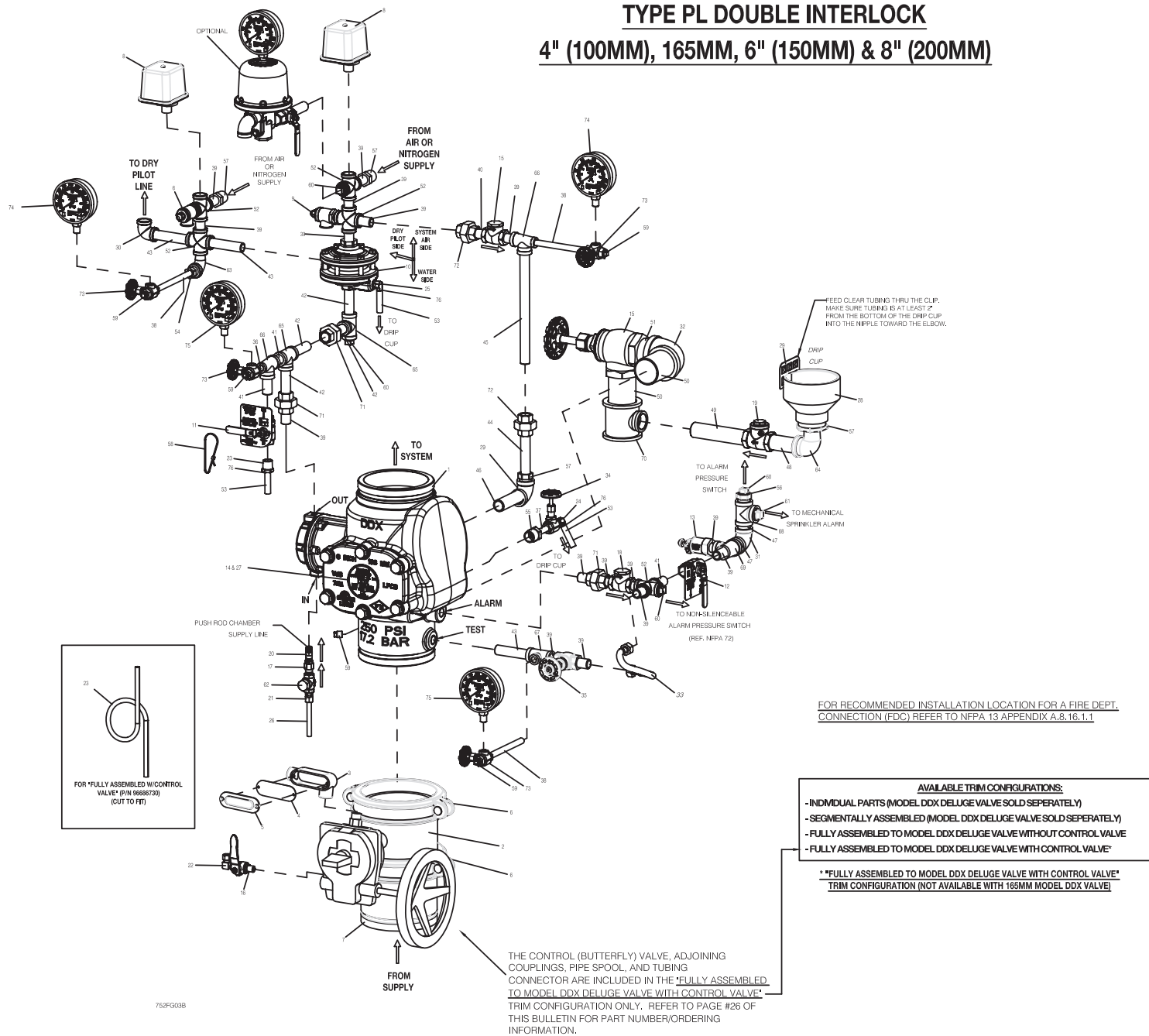

Fig. 3

Large DDX TYPE PL Trim (Refer to Fig. 3)

Item No.	Part No.			Description	QTY.
	Galvanized	Brass	Black Pipe		
1	6103060024	6103060024	6103060024	Valve Assembly, 4" (100mm) - For 4" Assembly Only	1
	6103040026	6103040026	6103040026	Valve Assembly, 6" (150mm) - For 6" Assembly Only	
	6103060028	6103060028	6103060028	Valve Assembly, 165mm - For 165mm Assembly Only	
	6103080001	6103080001	6103080001	Valve Assembly, 8" (200mm) - For 8" Assembly Only	
2	7M99002655	7M99002655	7M99002655	Butterfly Valve, 4" - For 4" Assembly Only	1
	7M99002656	7M99002656	7M99002656	Butterfly Valve, 6" - For 6" Assembly Only	
	7M99002657	7M99002657	7M99002657	Butterfly Valve, 8" - For 8" Assembly Only	
3	98020036	98020036	98020036	Conduit Body, 1/2"	1
4	98020034	98020034	98020034	Conduit Cover Gasket, Neoprene	1
5	98020033	98020033	98020033	Conduit Body Cover	1
6	7G05161600	7G05161600	7G05161600	Rigid Coupling, 4" - For 4" Assembly Only	2
	7G05242400	7G05242400	7G05242400	Rigid Coupling, 6" - For 6" Assembly Only	
	7G05323200	7G05323200	7G05323200	Rigid Coupling, 8" - For 8" Assembly Only	
7	91004004	91004004	91004004	Inlet Spool, 4" - For 4" Assembly Only	1
	91004006	91004006	91004006	Inlet Spool, 6" - For 6" Assembly Only	
	91004008	91004008	91004008	Inlet Spool, 8" - For 8" Assembly Only	
8	6990019313	6990019313	6990019313	Potter Pressure Switch, PS25-2 (cULus/FM)	2
	6990019536	6990019536	6990019536	Potter Pressure Switch, PS25-2 (VdS)	
9	98840195	98840195	98840195	Pressure Relief Valve (33 psi)	2
10	71030020	71030020	71030020	Model DI-SS Double Interlock Actuator	1
11	78653000	78653000	78653000	Manual Emergency Station Assembly	1
12	78653004	78653004	78653004	Valve Caution Station Assembly	1
13	78653100	78653100	78653100	Ball Drip Valve, 1/2"	1
14	99080002	99080002	99080002	Adhesive Pad	1
15	98840100	98840100	98840100	Angle Valve, 2"	1
16	98840117	98840117	98840117	Ball Valve, 1/4" NPTF x 1/4" NPTM	1
17	98840188	98840188	98840188	Check Valve, 1/4" NPTM x 1/4" NPTF	1
18	98840181	98840181	98840181	Check Valve, Horizontal Swing, 1/2" NPT	2
19	98840145	98840145	98840145	Check Valve, Horizontal Swing, 1" NPT	1
20	98840147	98840147	98840147	Check Valve, Inline Poppet, 1/4"	1
21	92056702	92056702	92056702	Compression Connector, 3/8" ID Tube x 1/4" NPT	1
22	92056703	92056703	92056703	Compression Connector, Elbow 3/8" ID Tube x 1/4" NPT	1
23	92056810	92056810	92056810	Connector, 3/8" ID Tube x 1/2" NPT	1
24	92056705	92056705	92056705	Connector, Elbow, 3/8" ID Tube x 1/4" NPT	1
25	92056704	92056704	92056704	Connector, Elbow, 3/8" ID Tube x 1/2" NPT	1
26	96686722	96686722	96686722	Copper Tubing, 3/8" OD x 2 ft.	1
27	94616931	94616931	94616931	Double Interlock Type PL Nameplate	1
28	98050004	98050004	98050004	Drain Cup, PVC	1
29	95306270	95306270	95306270	Drain Hose Clip	1

Item No.	Part No.			Description	QTY.
	Galvanized	Brass	Black Pipe		
30	98174401	98174440	98164401	Elbow, 1/2"	1
31	98174402	98174441	98164400	Elbow, 3/4"	2
32	98174405	98174444	98164405	Elbow, 2"	1
33	96920912	96920912	96920912	Flex Line, 1/2"	1
34	98840172	98840172	98840172	Globe Valve, 1/4"	1
35	98840171	98840171	98840171	Globe Valve, 1/2"	1
36	98543226	98533226	98523213	Nipple 1/4" x 1 1/2"	1
37	98543225	98533225	98573220	Nipple 1/4" x 2 1/2"	1
38	98543217	98533217	98523217	Nipple 1/4" x 6"	3
39	98543223	98533223	98523210	Nipple 1/2" x 1 1/2"	16
40	98543223	98533223	98523210	Nipple 1/2" x 1 1/2" (For 4" and 6" Valve Sizes Only)	1
	98543209	98533209	98523209	Nipple 1/2" x 2" (For 8" Valve Size Only)	
41	98543209	98533209	98523209	Nipple 1/2" x 2"	3
42	98543230	98533230	98523230	Nipple 1/2" x 3"	4
43	98543216	98533216	98523216	Nipple 1/2" x 3 1/2"	3
44	98543228	98533228	98523234	Nipple 1/2" x 4 1/2"	1
45	98543228	98533228	98523234	"Nipple 1/2" x 4 1/2" (For 8" Valve Size Only)"	1
	98543252	98533252	98523232	Nipple 1/2" x 10 1/2" (For 4" and 6" Valve Sizes Only)	
46	98543234	98533253	98523247	Nipple 3/4" x 3 1/2" (For 6" and 8" Valve Sizes Only)	1
	98543282	98533282	98523253	Nipple 3/4" x 4" (For 4" Valve Size Only)	
47	98543279	98533279	98523241	Nipple 3/4" x Close	2
48	98543222	98533222	98523224	Nipple 1" x 3 1/2"	1
49	98543266	98533266	98523228	Nipple 1" x 6"	1
50	98543262	98533262	98523262	Nipple 2" x 3 1/2"	2
51	98543238	98533238	98523254	Nipple 2" x Close	1
52	98750003	98750033	98750013	Pipe Cross, 1/2"	5
53	96686756	96686756	96686756	PVC Tubing, 3/8" ID x 6 ft.	1
54	98048000	98058000	98048020	Reducer Bushing, 1/2" x 1/4"	1
55	98048025	98058025	98048011	Reducer Bushing, 3/4" x 1/4"	1
56	98048022	98058022	98048012	Reducer Bushing, 3/4" x 1/2"	4
57	98048015	98048015	98048015	Reducer Bushing, 2" Spigot x 1" NPTF, PVC	1
58	89141112	89141112	89141112	Retaining Tie	9
59	98614403	98614412	98604403	Square Head Plug, 1/4"	5
60	98604406	98614411	98604402	Square Head Plug, 1/2"	4
61	98614401	98614413	98604401	Square Head Plug, 3/4"	1
62	98727607	98727607	98727607	Strainer, 1/4"	1
63	98174400	98174446	98164409	Street Elbow, 1/2"	1
64	98174416	98174449	98174412	Street Elbow, 1"	1
65	98761651	96606915	98761603	Tee, 1/2"	2
66	98761649	96606916	98761604	Tee, 1/2" x 1/4" x 1/2"	2
67	96606607	96606912	98761605	Tee, 1/2" x 1/2" x 1/4"	1
68	96606601	96606911	98766521	Tee, 3/4"	1
69	96606612	96606913	98761614	Tee, 3/4" x 1/2" x 1/2"	1
70	96606627	96606914	98761618	Tee, 2" x 2" x 1"	1
71	98815200	*98815300	98805200	Union, 1/2"	3
72	98815204	N/A	98845204	Union, 1/2", O-ring Seal	2
73	98840160	98840160	98840160	Valve, 3-way, 1/4"	4
74	98248000	98248000	98248000	Air Pressure Gauge (0-80 psi)	2
75	98248001	98248001	98248001	Water Pressure Gauge (0-300 psi)	2
76	95306255	95306255	95306255	Hose Clamp	3

*5 qty. of p/n 98815300 for brass trim only.

RELIABLE MODEL B1 ACCELERATOR KIT (P/N 651600003)

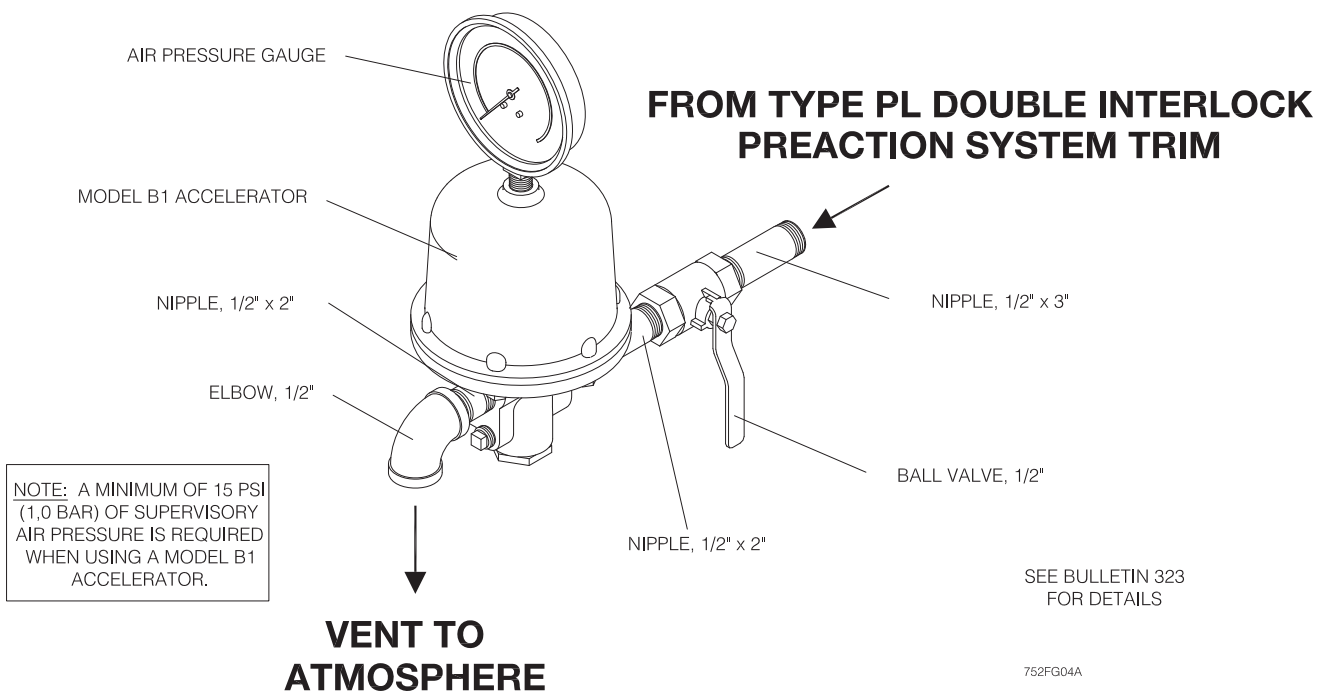

Fig. 4

System Operation

When set correctly for service, the Model DDX Deluge Valve is hydraulically established to withhold the supply water from the sprinkler system piping. The Reliable Model DDX Deluge Valve is shown in both closed and open positions in Fig. 1. In the closed position, the supply pressure acts on the underside of the clapper and also on the push rod through the push rod chamber's inlet restriction. The resultant force due to the supply pressure acting on the push rod is multiplied by the mechanical advantage of the lever and is more than sufficient to hold the clapper closed against normal supply pressure surges.

Whenever a fire is detected (i.e. via thermal detector or manual emergency station) and a sprinkler head is opened, the Model DDX Deluge Valves push rod chamber will be vented to atmosphere through the chamber's outlet. Since the pressure can not be replenished through the inlet restriction as rapidly as it is vented, the pushrod chamber pressure falls instantaneously. When the pushrod chamber pressure approaches approximately one-third of the supply pressure, the upward force of the supply pressure acting beneath the clapper overcomes the lever applied force, thereby opening the clapper.

Once the clapper has opened, the lever acts as a latch, preventing the clapper from returning to the closed position. Water from the supply flows through the Deluge Valve into the sprinkler system piping. Water also flows through the Deluge Valve alarm outlet to the alarm devices.

After system shutdown, resetting the Model DDX Deluge Valve is quite simple. Doing so only requires pushing in and turning the reset knob at the rear of the valve (see Fig 1). The external reset feature of the Model DDX Deluge Valve provides a means for simple, economical system testing, which is one essential facet of a good maintenance program. The external reset feature does not, however, eliminate another important facet of

good maintenance, namely, periodic cleaning and inspection of the internal valve parts.

In the event that water builds up inside the valve due to condensate from the air supply system or water left inside from valve system testing, a drain is available for venting. After closing the main supply valve, a small valve over the drain cup can be opened slightly until the water inside the valve body and the main pipe column has drained. See the section titled "Draining Excess/Condensate Water From System" in this bulletin for the detailed procedure.

The Model B Manual Emergency Station (see Fig. 5) is also included in the Reliable Type PL Double Interlock Preaction System trim sets. It consists of an aluminum nameplate mechanically attached to a ball valve. The valve handle in its OFF position is guarded against accidental turning to the ON position (and system discharge) by a nylon cable tie provided with each trim kit. The cable tie is inserted, as shown in Fig. 5, after the system has been restored for operation. The nylon cable tie is designed to allow, in case of an emergency, forceful turning of the valve handle to the ON position. As an alternative to the Model B Hydraulic Manual Emergency Station, the Model A Hydraulic Manual Emergency Pull Box (see Reliable Bulletin 506) is also available and can be provided as an option.

Whenever ambient temperature conditions are high, the water temperature in the Model DDX Deluge Valve's pushrod chamber could possibly increase, thereby increasing the pressure in the chamber to values exceeding the rated pressure of the system. In an indoor installation where standard room temperatures are exceeded, a pressure relief kit may be needed. Pressure relief kit, P/N 6503050001, can be installed into the pushrod chamber's releasing line to limit the pressure to 250 psi (17.2 bar).

Reliable Model DDX Deluge Valve with associated Type PL Double Interlock Preaction Trims sizes 2" (50 mm), 2½" (65 mm), 76 mm, 3" (80 mm), 4" (100 mm), 165 mm, 6" (150 mm) and 8" (200 mm) are rated for use at a minimum water supply pressure of 20 psi (1.4 bar) and a maximum water supply pressure of 250 psi (17.2 bar) for 2" (50mm), 2½" (65mm), 3" (80mm), 76mm and 8" (200mm) valve sizes and 300 psi (20.7 bar) for 4" (100mm), 6" (150mm) and 165mm valve sizes. Water supplied to the inlet of the valve and to the push rod chamber must be maintained between 40°F (4°C) and 140°F (60°C).

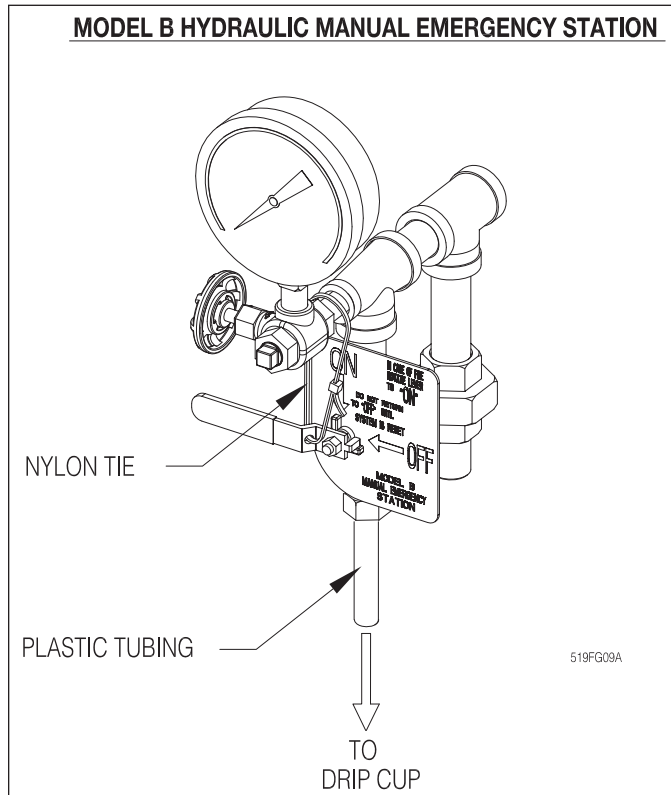

Fig. 5

Pressurizing Line Connection

The water supply for the push-rod chamber must be provided by connection of its inlet pressurizing line to the water supply piping. Pressurizing lines for multiple Model DDX Deluge Valve push-rod chambers must never be manifolded together, having only a single tap on the water supply piping. Each Model DDX Deluge Valve must have its own push-rod chamber pressurizing line connection.

This connection must be made on the supply side of the water supply control valve (see Fig. 2 or Fig. 3). This can be accomplished by:

- Using a tapped connection directly below or next to the main water supply control valve using a welded outlet or the appropriate mechanical fittings. A grooved-end outlet coupling is one way to achieve this; or
- Using a water supply control valve that has an available threaded (NPT) supply-side tap design to allow for a direct water supply connection to the Model DDX Deluge Valve's push-rod chamber.

Caution: Reliable's DDX valve is designed with an inlet restriction built into the pushrod chamber. It is important not to introduce additional restrictions into the direct water supply connection or the discharge from the pushrod chamber by installing additional valves or improperly installing the copper lines used in the trim of the valve.

Hydrostatic Testing of DDX Valves and DDX Systems

As required by NFPA 13, fire sprinkler systems with working pressures up to and including 150 psi are to be hydrostatically tested at a water pressure of 200 psi and maintain that pressure without loss for two hours. Fire sprinkler systems with working pressures above 150 psi are required to be hydrostatically tested at 50 psi above the system working pressure and maintain that pressure without loss for two hours. In addition to the hydrostatic tests described above, dry pipe and double interlock preaction systems require an additional low pressure air test.

In some cases, hydrostatic testing (in accordance with the NFPA 13 requirements noted above) will result in pressures that exceed the working pressure of the valve and trim kit for the two-hour test period. **The valve and applicable trim kit have been tested, approved and listed under these conditions and as such, hydrostatic testing in accordance with NFPA 13 is acceptable. In addition, the clapper can remain in the closed position and the trim kit need not be isolated, as each has been designed to withstand hydrostatic testing as required by NFPA 13.**

Hydrostatically testing the valve and trim to pressures higher than their rating is limited to the hydrostatic test as referenced by NFPA 13. It does not address the occurrence(s) of a "water hammer" effect, which can indeed damage the valve. A "water hammer" in the water supply piping of the valve can create pressures in excess of the rated pressure and should be avoided by all necessary means. This condition may be created from improper fire pump settings, underground construction work, or an improper venting of trapped air in the water supply piping.

System Design Considerations

The automatic sprinklers, air compressor, pilot line detectors, manual pull stations, and signaling devices which are utilized with the Type PL Double Interlock Preaction System must be UL or ULC Listed or FM Approved, as applicable.

Factory Mutual requires that detection devices in refrigerated areas be of the fixed temperature type. In addition, they must have a temperature rating lower than that of the sprinklers and preferably as low as possible for the given ambient conditions.

The Deluge Valve, and all interconnecting piping must be located in a readily visible and accessible location and in an area that can be maintained above 40°F (4°C). **Note:** Heat Tracing is not permitted.

Pendent sprinklers, other than dry pendants, used on preaction systems shall be installed on return bends per NFPA 13.

System Air/ Nitrogen Pressure Requirements

The system trim includes gauges to read the pneumatic and water pressures of the Type PL Double Interlock Preaction System. Table A specifies the air or nitrogen pressure to be constantly applied to the system. A properly design pneumatic supply system automatically regulates pressure, provides a safeguard against small pressure leaks in the sprinkler piping, and properly restricts the flow of makeup air or nitrogen from the source.

When the optional Reliable Model B1 Accelerator is used to expedite water delivery time, and/or when an PS25-2 high/low pressure switch is used, the pneumatic pressure must not be less than 15 psi (1.0 bar). See Reliable Bulletin 254 for complete information on air and nitrogen regulating equipment.

Table A

Water Pressure psi (bar)	Pneumatic Pressure to be Pumped into Sprinkler System psi (bar)	
	Maximum	Not Less Than
20 (1.4)	8 (0.6)	10 (0.7)
30 (2.1)	10 (0.7)	14 (1.0)
50 (3.4)	12 (.8)	16 (1.1)
75 (5.2)	13 (.9)	17 (1.2)
100 (6.9)	15 (1.)	19 (1.3)
125 (8.6)	16 (1.1)	20 (1.4)
150 (10.3)	17 (1.2)	21 (1.4)
175 (12.1)	18 (1.2)	22 (1.5)
200 (13.8)	19 (1.3)	23 (1.6)
225 (15.5)	21 (1.4)	25 (1.7)
250 (17.2)	22 (1.5)	26 (1.8)
275 (19.0)	23 (1.6)	27 (1.9)
300 (20.7)	24 (1.7)	28 (1.9)

Note: During system set-up, a higher pneumatic pressure may be required in order to properly set the Model LP Dry Pilot Actuator. The dew point of the air supply must be maintained below the lowest ambient temperature to which the preaction system will be exposed. Otherwise, accumulation of water (condensate) on the air side of the Actuator can lower the air pressure at which the Actuator opens, and possibly prevent proper system operation. Also, introduction of moisture into the system piping exposed to freezing temperatures can create ice blockage, which could prevent proper system operation. As a minimum, the supply of air should be taken from the area of lowest temperature within the protected area. The air supply system must be carefully designed to prevent plugging by frost deposits. Special requirements, such as those in FME&R's "Installation Guidelines for Refrigerated Storage" may need to be incorporated.

Nitrogen used in refrigerated area systems minimizes a possibility of ice build up and blockage inside the system piping that could inhibit proper system operation. The dew point of nitrogen compressed to 20 psig (1.4 bar) pressure is -46°F (-43.3°C) and -52°F (-46.7°C) when compressed to 10 psig (0.7 bar). High pressure nitrogen cylinders can typically be rented from a local source, with rental fees varying by supplier and cylinder sizes. Typical cylinders are described in Table B. the calculated nitrogen supply in lbs (kgs) to pressurize various system capacities to 10 psi (0.7 bar) at different freezer temperatures is shown in Table C.

Table B

Cylinder Size	"Q"	"S"	"K"	"T"
Nitrogen Weight lbs (kg)	5.50 (2.49)	10.28 (4.66)	16.51 (7.49)	22.01 (9.98)
Nitrogen Volume ft ³ (m ³)	76 (2.2)	142 (4.)	228 (6.5)	304 (8.6)
Pressurized at psi (bar)*	2200 (151.7)	2200 (151.7)	2200 (151.7)	2460 (169.6)

Note: Initial pressure and thus nitrogen weight and volume can vary slightly. Check with your local supplier.

Table C

System Capacity Gal. (L)	Freezer Temperature, °F (°C)					Approx. Fill Time (min*)
	20 (-6.7)	0 (-18)	-20 (-29)	-40 (-40)	-60 (-51)	
250 (946)	1.90 (0.86)	1.90 (0.86)	2.00 (0.91)	2.10 (0.95)	2.20 (1.00)	1
500 (1893)	3.64 (1.65)	2.80 (1.27)	4.00 (1.81)	4.20 (1.91)	4.40 (2.00)	2
750 (2839)	5.50 (2.49)	5.70 (2.59)	6.00 (2.72)	6.30 (2.86)	6.60 (2.99)	3
1000 (3785)	7.30 (3.31)	7.60 (3.45)	8.00 (3.63)	8.33 (3.78)	8.80 (3.99)	4

Note: To obtain required nitrogen supply (lbs.) for 15 psi (1.0 bar) or 22 psi (1.5 bar), multiply the tabulated values by a factor of 1.5 or 2.2 respectively.

(1 bar = 100kPa)

* When filled with the Reliable Model A-2 Pressure Maintenance Device having the bypass valve open

Whenever multiple Type PL Preaction systems are supplied by a common air or nitrogen source, each system must have its own pressure maintenance device for individual maintenance of pressure (NFPA 13, 7.2.6.5).

Low Air/Nitrogen Pressure Supervision

The double interlock function is achieved by the operation of the Model LPDI Double Interlock Actuator due to sprinkler operation and pilot line detector activation.

Two Potter pressure switches, Model PS25-2, are provided with the Type PL Double Interlock Preaction System trim for low air pressure supervision. The electrical rating for this pressure switch is 10.0 A, hp @ 125/250 VAC; 2.5 A @ 6/12/24 VDC. These will provide a supervisory signal for identifying a low air pressure supply condition at 4 to 8 psi (0.3 to 0.4 bar) decreasing pressure. For systems utilizing air or nitrogen pressure below 15 PSI, it will be necessary to replace the PS25-2 low pressure switch with an PS10-2 switch.

Double Interlock Preaction System Pneumatic/Pneumatic Release Trim (Type PL) Engineering Specifications

General Description

Preaction system shall be a double Interlock preaction system utilizing a [2" (50 mm)][2½" (65 mm)][76 mm][3" (80 mm)][4" (100 mm)][165 mm][6" (150 mm)][8" (200 mm)] [cULus Listed] [FM Approved] hydraulically operated, differential latching clapper-type valve with pneumatic-pneumatic double interlock preaction trim. Deluge Valve construction shall be of lightweight, ductile iron construction with either a "screw in" stainless steel seat and clapper assembly or drop in bronze seat and clap-

per assembly. Stainless steel or Bronze seat shall have O-ring seals to resist leakage and corrosion. Clapper facing shall be pressure actuated, providing a limited compression seat for the sealing force between the clapper rubber facing and the valve seat. Deluge valve shall have an external reset knob for resetting the clapper without requiring the removal of the valve face plate. Push-rod chamber design shall consist of a stainless steel piston/ push-rod and spring assembly with diaphragm seal secured to the casting through a push-rod guide constructed of a synthetic engineering plastic to resist corrosion. Casting shall have a bleeder hole located on the pushrod chamber for air/ water leakage indication. Trip ratio shall be approximately a 3:1 force differential. Deluge valve shall be of the straight through design to minimize friction loss. Inlet restriction orifice shall be factory installed into the inlet port of the deluge valve push-rod cover plate and not be a separate part of the deluge valve trim. End connection style to be [2" (50 mm)][2½" (65 mm)][76 mm][3" (80 mm)][4" (100 mm)][165 mm][6" (150 mm)][8" (200mm)] grooved, per ANSI/AWWA C606 or flanged per ASME B16.5 or ISO 7005. Deluge valve shall have a rated working pressure of 250 psi (17.2 bar) for 2" (50 mm), 2½" (65 mm), 3" (80mm), 76 mm and 8" (200 mm) valve sizes and 300 psi (20.7 bar) for 4" (100 mm), 6" (150 mm) and 165mm valve sizes. Deluge valve to be [2" (50 mm)][2½" (65 mm)][76 mm][3" (80 mm)][4" (100 mm)][165 mm][6" (150 mm)][8" (200 mm)] Reliable Model DDX Deluge Valve (Bulletin 519). Valve trim shall be Type PL pneumatic/pneumatic double interlock trim consisting of the following components:

- Hydraulic trim shall be either galvanized and brass components specifically or black pipe with brass components Listed/Approved with the deluge valve, including an emergency release valve and 1¼" or 2" main drain. Deluge valve's releasing devices shall be a low-pressure pneumatic double interlock actuator.
- The low-pressure, pneumatic double interlock actuator shall be of stainless steel construction utilizing two diaphragm and compression spring design to separate the push-rod chamber water pressure from the system piping's pneumatic supervisory pressure and the pilot line pneumatic pressure. The low-pressure actuator shall only require between 8 and 28 psi (0.6 to 1.9 bar) supervisory pressure and pilot line pressure for proper setting in accordance with the manufacturer's instructions. Low-pressure pneumatic actuator shall be Reliable Model LPDI Double Interlock Actuator.
- The low air supervisory pressure switch to indicate loss of air pressure in system piping shall be [cULus Listed] [FM Approved] and of the bellows-activated type enclosed in a weatherproof, 4x, NEMA 4-rated enclosure incorporating tamper-resistant screws. There shall be two sets of SPDT (Form C) contacts rated at 10.0 A @ 125/250 VAC and 2.5 A @ 6/12/24 VDC. The pressure switch shall have a maximum service pressure rating of 250 psi (17.2 bar). Switch shall be provided with a ½" NPT male pressure connection. Low air supervisory pressure switch shall be Potter PS25-2.

Type PL Double Interlock Preaction System shall be a Reliable Double Interlock Type PL Preaction System, Bulletin 752.

Supervisory Air Supply Options

Note: See Reliable Bulletin 254 for complete information on air and nitrogen regulating equipment.

Owner's Air Supply

Supervisory air supply shall be provided by an owner supplied air system in conjunction with a [cULus Listed] [FM Approved] automatic pressure maintenance device, capable of maintaining a constant system pressure regardless of pressure fluctuations in the compressed air source. The pressure maintenance device shall consist of galvanized trim and brass parts, including a strainer and a field adjustable air pressure regulator, and have a working pressure rating of 175 psi (12.1 bar). The pressure regulator shall have an adjustable outlet pressure range of 5 to 100 psi (0.34 to 6.8 bar). Pressure maintenance device shall be Reliable Model A-2.

Compressed Air Supply

Supervisory air supply shall be provided by an automatic air compressor sized for the capacity (volume) of the double interlock preaction system piping, and be capable of restoring normal air pressure in the system within the time limits specified by NFPA 13. Double interlock preaction system shall only require between 8 and 28 psi (0.6 to 1.9 bar) supervisory pressure for proper setting of the low pressure pneumatic actuator in accordance with the manufacturer's instructions. Air supply shall be equipped with an automatic pressure maintenance device capable of maintaining a constant system pressure. The pressure maintenance device shall consist of galvanized trim and brass parts, including a strainer and a field adjustable air pressure regulator or pressure switch, and have a working pressure rating of 175 psi (12.1 bar). The pressure regulator shall have an adjustable outlet pressure range of 5 to 100 psi (0.34 to 6.8 bar). Pressure maintenance device shall be Reliable Model A-2 or Reliable Model B-1. (**Note:** For small systems with air compressors having a capacity less than 5.5 cfm @ 10 psi, a pressure maintenance device is not required per NFPA 13. Consideration should be given, however, to the impact of a direct air supply on the overall performance of the system.)

Nitrogen

Nitrogen cylinders provided by an approved source shall provide the nitrogen supply. Double interlock preaction system shall only require between 8 and 28 psi (0.6 to 1.9 bar) supervisory pressure for proper setting of the low pressure pneumatic actuator in accordance with the manufacturer's instructions. The nitrogen cylinder pressure shall be regulated and supervised through the use of nitrogen regulating device and low-pressure trim kit. This device shall consist of a brass, single stage pressure regulator, equipped with high pressure inlet and low pressure outlet gauges, and ¼" copper connection tubing with galvanized ¾" x ¼" reducer bushing. Optional: Low-pressure trim kit shall be included to monitor the regulated nitrogen supply pressure to provide a low-pressure supervisory alarm. This kit shall include a low-pressure switch with associated galvanized connection trim. Assembly shall be a Reliable Nitrogen Regulating Device. This device is to be used in conjunction with the Reliable Model A-2 Pressure Maintenance Device.

Optional System Accessories **System Control Valve**

Preaction system control valve shall be a slow close, [cULus Listed] indicating butterfly type valve with a pre-wired supervisory tamper switch assembly. The valve shall be rated for a working pressure of [300 psi (20.7 bar)]. System control valve shall be for a [2" (50 mm)] Gruvlock AN7722-3A Butterfly Valve or [2½" (65 mm)][3" (80 mm)][4" (100 mm)][6" (150 mm)][8" (200 mm)] - Nibco GD-4765-8N Butterfly Valve.

Accelerator

For system capacities in accordance with NFPA 13, an accelerator with associated galvanized trim kit shall be provided to exhaust air pressure from the pneumatic actuator trim piping in order to hasten operation of the double interlock preaction system. Minimum pneumatic pressure shall be 15 psi (1.0 bar) to ensure proper accelerator operation. Accelerator shall be [cULus Listed] [FM Approved] for use with the double interlock preaction trim. Accelerator shall be capable of adjusting for small fluctuations in system air pressure without causing operation. The accelerator shall contain an integral Accelo-Check (anti-flooding) assembly to prevent entry of water and debris into critical internal areas during operation. Accelerator body and dome to be of cast aluminum and epoxy coated inside and out. Diaphragm construction shall consist of Dupont Fairprene BN 5049 with stainless steel filter assembly. Trim kit shall consist of all galvanized and brass parts, including an isolating ball valve. Accelerator and trim kit shall be Reliable Model B1 Accelerator Trim Kit.

Waterflow Alarm Pressure Switch

Alarm pressure switch shall be provided to indicate water flow and provide a water flow alarm. Pressure switch shall be [cULus Listed] and of the bellows activated type enclosed in a weather-proof, NEMA 4/4X rated enclosure incorporating tamper-resistant screws. There shall be two sets of SPDT (Form C) contacts rated at 10.0 A @ 125/250 VAC and 2.5 A @ 6/12/24 VDC. The pressure switch shall have a maximum service pressure rating of 250 psi (17.2 bar) and shall be factory adjusted to operate at a pressure of 4 to 8 psi (0.27 to 0.55 bar) with adjustment up to 15 psi (1.03 bar). Switch shall be provided with a 1/2" NPT male pressure connection. Waterflow alarm pressure switch shall be Potter PS10-2.

Technical Data

Reliable Double Interlock Type PL Preaction Systems, with associated trim, size 2" (50 mm), 2½" (65 mm), 76 mm, 3" (80 mm), 4" (100 mm), 165 mm, 6" (150 mm), 8" (200 mm) are rated for use at minimum water supply pressure of 20 psi (1.4 bar) and maximum supply pressure of 250 psi (17.2 bar) for 2" (50 mm), 2½" (65 mm), 3" (80 mm), 76 mm and 8" (200 mm) valve sizes and 300 psi (20.7 bar) for 4" (100 mm), 6" (150 mm) and 165 mm valve sizes. Water supplied to the inlet of the valve and to the pushrod chamber must be maintained between 40°F (4°C) and 140°F (60°C).

The following list of technical bulletins pertains to valves and devices that may be used in this preaction system:

Deluge Valve	Reliable 518/519
Hydraulic Emergency Station (Model A)	Reliable 506
Mechanical Sprinkler Alarm	Reliable 612/613
Pressure Maintenance Device	Reliable 254
Nitrogen Regulating Device	Reliable 254
Air Compressor	Gast F-30
Pilot Line Detectors	Reliable 180
Model B1 Accelerator Trim Kit	Reliable 323
Low Air Pressure Supervisory Switch	Potter 5401564
Waterflow Pressure Alarm Switch	Potter 5400928

Model DDX Deluge Valve Description

- Rated working pressure:
Valve & System - 250 psi (17.2 bar) for 2" (50mm), 2½" (65mm), 3" (80mm), 76mm and 8" (200mm) valve sizes and 300 psi (20.7 bar) for 4" (100mm), 6" (150mm) and 165mm valve sizes.
- Factory tested to a hydrostatic pressure of 500 psi (34.5 bar) for 2" (50mm), 2½" (65mm), 3" (80mm), 76mm and 8" (200mm) valve sizes and 600 psi (41.4 bar) for 4" (100mm), 6" (150mm) and 165mm valve sizes. (Valve only)
- End and trim connections:
 - ANSI/AWWA C606 grooved inlet and outlet

Nominal Pipe Size	Outlet Diameter	Groove Diameter	Groove Width	Outlet Face to Groove
2" (50 mm)	2.375" (60mm)	2.250" (57mm)	11/32" (9.0mm)	5/8" (16mm)
2½" (65 mm)	2.875" (73mm)	2.720" (69mm)	11/32" (9.0mm)	5/8" (16mm)
76 mm	3.000" (76mm)	2.845" (72mm)	11/32" (9.0mm)	5/8" (16mm)
3" (80 mm)	3.500" (89mm)	3.344" (85mm)	11/32" (9.0mm)	5/8" (16mm)
4" (100 mm)	4.500" (114mm)	4.334" (110mm)	3/8" (9.5mm)	5/8" (16mm)
165 mm	6.500" (165mm)	6.330" (161mm)	3/8" (9.5mm)	5/8" (16mm)
6" (150 mm)	6.625" (168mm)	6.455" (164mm)	3/8" (9.5mm)	5/8" (16mm)
8" (200 mm)	8.625" (219mm)	8.441" (214mm)	7/16" (11mm)	3/4" (19mm)

- Threaded openings Per ANSI B 2.1
- Flange Dimensions

Flange Type:	Nominal Pipe Size	Bolt Circle Diameter	Bolt Hole Diameter	Flange Outside Diameter	Flange Thickness	Number of Bolts
ASME B16.5 Class 150	4" (100mm)	7½" (191mm)	¾" (19mm)	9" (229mm)	15/16" (24mm)	8
ISO 7005-2 PN16	4" (100mm)	7¾" (180mm)	¾" (19mm)	9" (229mm)	15/16" (24mm)	8
ASME B16.5 Class 150	6" (150mm)	9½" (241mm)	7/8" (22mm)	11" (279mm)	15/16" (24mm)	8
ISO 7005-2 PN16	6" (150mm)	9 7/16" (240mm)	29/32" (23mm)	11" (279mm)	15/16" (24mm)	8
ASME B16.5 Class 150	8" (200mm)	11¾" (298mm)	7/8" (22mm)	13½" (343mm)	1" (25.4mm)	8
ISO 7005-2 PN16	8" (200mm)	11 5/8" (295mm)	29/32" (23mm)	13½" (343mm)	1" (25.4mm)	12

- Valve Exterior Color:

Valve Size	Color

2" (50 mm)	Black or Red
2½" (65 mm)	Black or Red
76 mm	Red
3" (80 mm)	Black or Red
4" (100 mm)	Black or Red
165 mm	Red
6" (150 mm)	Black or Red
8" (200 mm)	Black or Red

5. Face to face dimensions:

Valve Size:	End Connection:	End to End:
2" (50mm), 2½" (65mm), 76mm & 3" (80mm)	Groove/ Groove	12½" (318mm)
4" (100mm)	Groove/ Groove	14" (356mm)
	Flange/ Groove	16" (406mm)
	Flange/ Flange	16" (406mm)
6" (150mm) & 165mm	Groove/ Groove	16" (406mm)
	Flange/ Groove	19" (483mm)
	Flange/ Flange	19" (483mm)
8" (200mm)	Groove/ Groove	19¾" (492mm)
	Flange/ Flange	21¼" (540mm)

6. Valve shipping weight:

Valve Size:	End Connection:	Weight:
2" (50mm), 2½" (65mm), 76mm & 3" (80mm)	Groove/ Groove	34 lbs (15 kg)
4" (100mm)	Groove/ Groove	64 lbs (29 kg)
	Flange/ Groove	79 lbs (36 kg)
	Flange/ Flange	92 lbs (42 kg)
6" (150mm) & 165mm	Groove/ Groove	95 lbs (43 kg)
	Flange/ Groove	122 lbs (56 kg)
	Flange/ Flange	138 lbs (69 kg)
8" (200mm)	Groove/ Groove	148 lbs (67 kg)
	Flange/ Flange	197 lbs (90 kg)

7. Trim shipping weight:

Trim Configuration	2" (50 mm), 2½" (65 mm), 3" (80 mm) & 76 mm	4" (100 mm), 6" (150 mm), 8" (200 mm) & 165 mm
Model DDX Double Interlock Type PL	49 (22.2 kg)	59 lbs (25.4 kg)

8. Friction loss (Expressed in equivalent length of Schedule 40 pipe, based on Hazen & Williams formula:

Valve Size:	Equivalent Length:		Cv
	C = 120	C = 100	
2" (50mm)	4.4 ft (1,3 m)	3.1 ft (1,0 m)	101
2½" (65mm)	6.0 ft (1,8 m)	4.3 ft (1,3 m)	236
76mm	7.7 ft (2,3 m)	5.5 ft (1,7 m)	241
3" (80mm)	12.6 ft (3,8 m)	9.0 ft (2,7 m)	254
4" (100mm)	14 ft (4,3 m)	10 ft (3,0 m)	469
165mm	29.4 ft (9,0 m)	20.9 ft (6,4 m)	886
6" (150mm)	29.4 ft (9,0 m)	20.9 ft (6,4 m)	886
8" (200mm)	53.5 ft (16,3 m)	38.1 ft (11,6 m)	1516

9. Installation position: Vertical

Trim Descriptions

The Type PL Double Interlock Preaction Trims for the Reliable Model DDX Deluge Valve are arranged for rapid, easy, and compact attachment, and serve as connection points to Reliable Model C Mechanical Alarms and other devices.

The Double Interlock Type PL Preaction System trim configurations can be ordered as individual parts, in time-saving segmentally assembled kit forms, or fully assembled to the Model DDX Deluge Valve (with or without a control valve).

Maintenance

Reliable Double Interlock Type PL Preaction Systems and associated equipment shall periodically be given a thorough inspection and test. NFPA 25, Inspection, Testing and Maintenance of Water Based Fire Protection Systems, provides minimum maintenance requirements. System components shall be tested, operated, cleaned, and inspected at least annually, and parts replaced as required.

Type PL Double Interlock Preaction Trim

Type PL Double Interlock Preaction trim (see Figures 2 and 3) utilizes a Model LPDI Double Interlock Actuator for releasing the Deluge Valve.

Type PL Double Interlock Preaction Trim installation on Model DDX Deluge Valves uses eight tapped openings for trim connections. Each opening and its function are indicated on Fig. 2 or Fig. 3. Using Fig. 2 or Fig. 3 as reference, the recommended trim installation is as follows:

1. Install ½" nipple (#40, Fig. 2 or #43, Fig. 3) in tapped opening marked "TEST." **Note: If interference occurs between the supply gauge and the control valve, the 1/4" plug (#60, Fig. 2 or #60, Fig. 3) in the opening marked "SUPPLY" may be swapped with: the 1/4" nipple (#38, Fig. 2), angle valve (#12, Fig. 2) and gauge (#75, Fig. 2) for the 2" (50mm), 2-1/2" (65mm), 76mm and 3" (80mm) valve sizes; 1/4" nipple (#37, Fig. 3), 1/4" elbow (#27, Fig. 3), 1/4" nipple (#38, Fig. 3), 3-way valve (#73, Fig. 3) and the gauge (#75, Fig. 3) for the 4" (100mm), 165mm and 6" (150mm) valve sizes; 1/4" nipple (#38, Fig. 3), 3-way valve (#73, Fig. 3) and the gauge (#75, Fig. 3) for the 8" (200mm) valve size, in the trim installed in the opening marked "TEST".**
2. Install ½" nipple (#45, Fig. 2 or #39, Fig. 3) in tapped opening marked "ALARM" and connect balance of this trim line.
3. Install ¼" plug (#60, Fig. 2 or #60, Fig. 3) in tapped opening marked "SUPPLY." **Note: If interference occurs between the supply gauge and the control valve, the 1/4" plug (#60, Fig. 2 or #60, Fig. 3) in the opening marked "SUPPLY" may be swapped with: the 1/4" nipple (#38, Fig. 2), angle valve (#12, Fig. 2) and gauge (#75, Fig. 2) for the 2" (50mm), 2-1/2" (65mm), 76mm and 3" (80mm) valve sizes; 1/4" nipple (#37, Fig. 3), 1/4" elbow (#27, Fig. 3), 1/4" nipple (#38, Fig. 3), 3-way valve (#73, Fig. 3) and the gauge (#75, Fig. 3) for the 4" (100mm), 165mm and 6" (150mm) valve sizes; 1/4" nipple (#38, Fig. 3), 3-way valve (#73, Fig. 3) and the gauge (#75, Fig. 3) for the 8" (200mm) valve size, in the trim installed in the opening marked "TEST".**



MODEL DDX HYDRAULIC FRICTION LOSS GRAPH

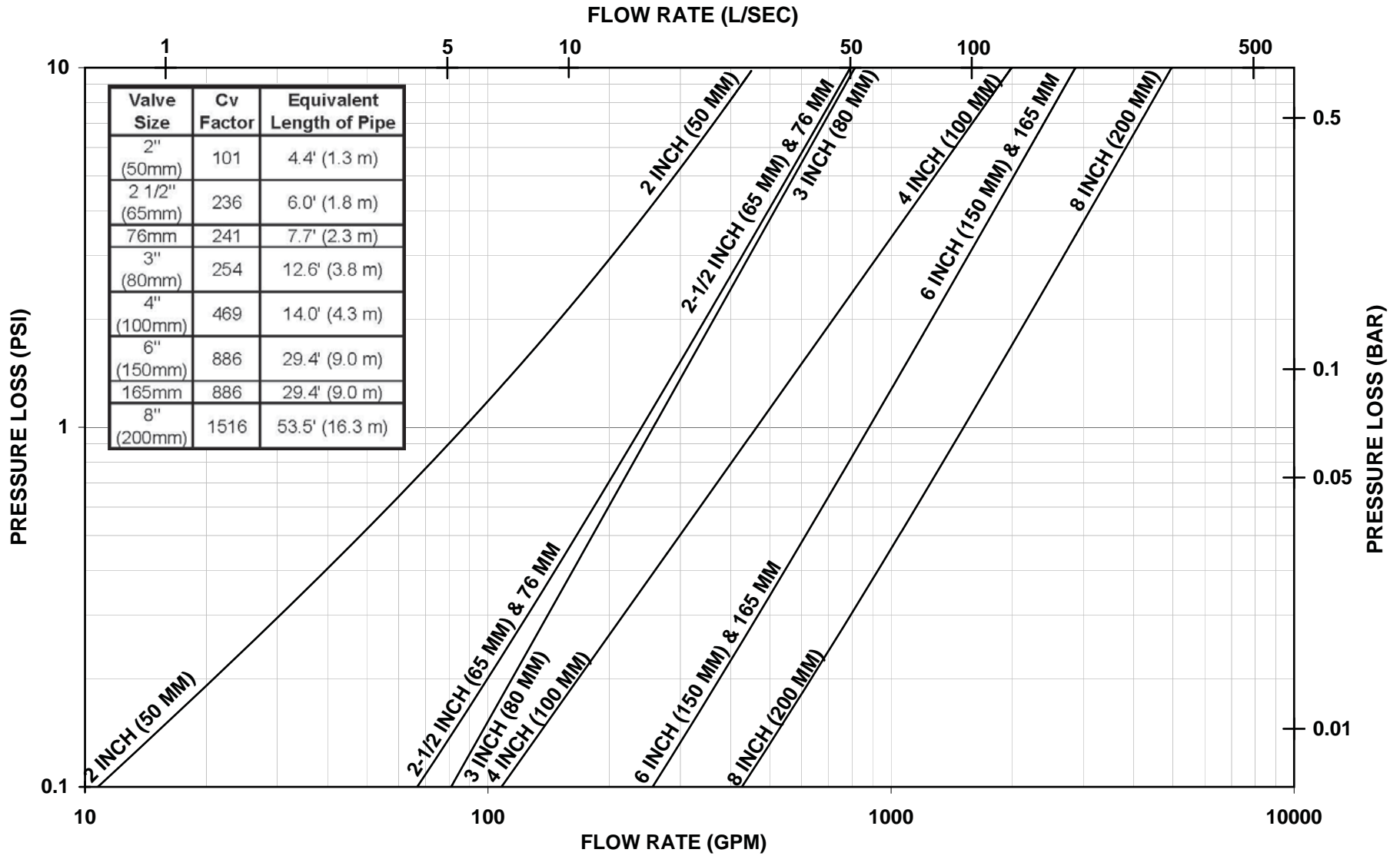

Fig. 6

8" (200mm) valve size, in the trim installed in the opening marked "TEST".

4. Install ½" nipple (#39, Fig. 2 or #39, Fig. 3) in tapped opening marked "OUT" and connect balance of this trim line.
5. Install ¼" inline check valve (#18, Fig. 2 or #17, Fig. 3) in tapped opening marked "IN" and connect balance of this trim line. Supply line must be connected to the inlet of the control valve for each Deluge Valve as shown. **Caution:** Over tightening check valve can cause a restriction in flow that may prevent the valve from "setting up".
6. Install 1¼" Nipple (#51, Fig. 2) or 2" nipple (#51, Fig. 3) in tapped drain opening and connect balance of this trim line.
7. Install ¾" x ¼" reducing bushing (#56, Fig. 2 or #56, Fig. 3) in the lower-most tapped opening at the rear of the Deluge Valve and connect the balance of this trim line.
8. Install ¾" nipple (#47, Fig. 2 or #46, Fig. 3) in the upper-most tapped opening at the rear of the Deluge Valve and connect the balance of this trim line.

Resetting the Model DDX Type PL Double Interlock Preaction System

Refer to Figs. 2, 3, 7, 8 and 9.

1. Close the main valve controlling water supply (Fig. 9) to the Deluge Valve and close off the air/nitrogen supply to the sprinkler system.
2. Close the pushrod chamber supply valve; valve A (Fig. 9).
3. Open the main drain valve, valve B (Fig. 9), and drain system.
4. Open all drain valves and vents at low points throughout the system, closing them when flow of water has stopped. Open valve D (Fig. 9). **Note:** The above steps accomplish the relieving of pressure in the pushrod chamber of the Deluge Valve.
5. With Valve F (Fig. 9) open, push in the plunger of ball drip valve, valve G (Fig. 9), to force the ball from its seat, and drain any water in the alarm line.
6. With the Model B Manual Emergency Station, valve D (Fig. 9), open, push in and rotate the Deluge Valve's external reset knob (#14, Fig. 7 or #38, Fig. 8) clockwise until you hear a distinct clicking noise, indicating that the clapper has closed. **Note:** The reset knob can be rotated only when pressure in the pushrod chamber is vented to atmospheric conditions (0 psig).
7. Inspect and replace any portion of the sprinkler system and/or pilot line subjected to fire conditions.
8. Close valve F (Fig. 9). Open valve A (Fig. 9) to begin pressurizing the push-rod chamber and its associated piping, while simultaneously venting any entrapped air. **Note:** This venting of the air from the actuation piping is very important to ensure proper system operation and avoidance of falsely tripping the Deluge Valve.
9. Upon seeing a solid flow of water from the drain tubing, and the cessation of the "gurgling" sound at the drip cup, H (Fig. 9), close valve D (Fig. 9) then rapidly apply compressed air or nitrogen into the Model LPDI Double Interlock Actuator (by pressurizing the sprinkler system and pilot line piping) until the pressure conforms to Table A levels as indicated on the air pressure gauges (Fig. 9). Either the pilot line or the

system piping can be filled first. The order of pressurizing the system piping and the pilot line is not critical. The Model LPDI Double Interlock Actuator will close during this pressurizing process and the water will stop flowing into the drip cup. **Note:** It may be necessary to temporarily close the main drain valve B (Fig. 9) in order to build sufficient air pressure to "set up" the Model LPDI Double Interlock Actuator. Once the Model LPDI Double Interlock Actuator is "set up", the main drain valve B (Fig. 9) should be reopened and the remaining procedure followed. At this point, the pressure gauge which indicates pushrod chamber pressure (Fig. 9) will equalize to the available water supply pressure. **Note:** It may be necessary to isolate the system pressure gauge in the supply line to the Model LPDI Double Interlock Actuator during system set-up by closing the ¼" 3-way valve (#73, Fig. 2 or #73 Fig. 3). During set-up, pressure fluctuations may occur that can be potentially damaging to the gauge.

10. If it is being used, reset the Model B1 Accelerator per Reliable Bulletin 323. **Note:** The Model B1 Accelerator requires a minimum of 15 psi (1.0 bar) for proper operation.
11. Open valve F (Fig. 9). Open slightly the main valve controlling water supply (Fig. 9) to the Model DDX Deluge Valve, closing drain valve B (Fig. 9) when water flows. Observe if water leaks through the ball drip valve, valve G (Fig. 9), into the drip cup, H (Fig. 9). If no leak occurs, the Deluge Valve's clapper is sealed. Open slowly, and verify that the main valve controlling water supply is fully opened and properly monitored.
12. Verify that valve A (Fig. 9) and valve F (Fig. 9) are open.
13. Secure the handle of the Model B Manual Emergency Station, valve D (Fig. 9), in the OFF position with a nylon tie (#59, Fig. 2 or #59, Fig. 3) see Fig. 5.

Inspection and Testing

Refer to Figs. 2, 3, 7, 8, and 9.

1. **Water supply** — be sure the valve(s) controlling water supply to the Deluge Valve are opened fully and properly monitored.
2. **Alarm line** — be sure that valve F (Fig. 9) is opened and remains in this position.
3. **Other trimming valves** — check that valve A (Fig. 9) is open as well as all of the pressure gauge's ¼" 3-way valves. Valves D, E, and J (Fig. 9) should be closed.
4. **Ball drip valve G (Fig. 9)** — make sure that valve F (Fig. 9) is open. Push in on the plunger to be sure the ball check is off its seat. If no water appears, the Deluge Valve's water seat is tight. Inspect the bleed hole (see Fig. 7 or Fig. 8)) on the underside of the push rod chamber for leakage.
5. **System pneumatic pressure** — check air pressure gauge (Fig. 9) and water supply pressure gauge (Fig. 9) for conformance to Table A.
6. **Releasing device** — Model LPDI Double Interlock Actuator (Fig. 9) — Verify that the outlet is not leaking water. Check the air pressure gauge (Fig. 9) for proper pressure setting. Verify that the tubing line from the Actuator is not pinched or crushed, which could prevent proper operation of the Deluge Valve.
7. **Testing alarms** — make sure that valve F (Fig. 9) is open. Open valve J (Fig. 9) permitting water from the supply to

MODEL DDX VALVE (SCREW-IN SEAT CONFIGURATION)

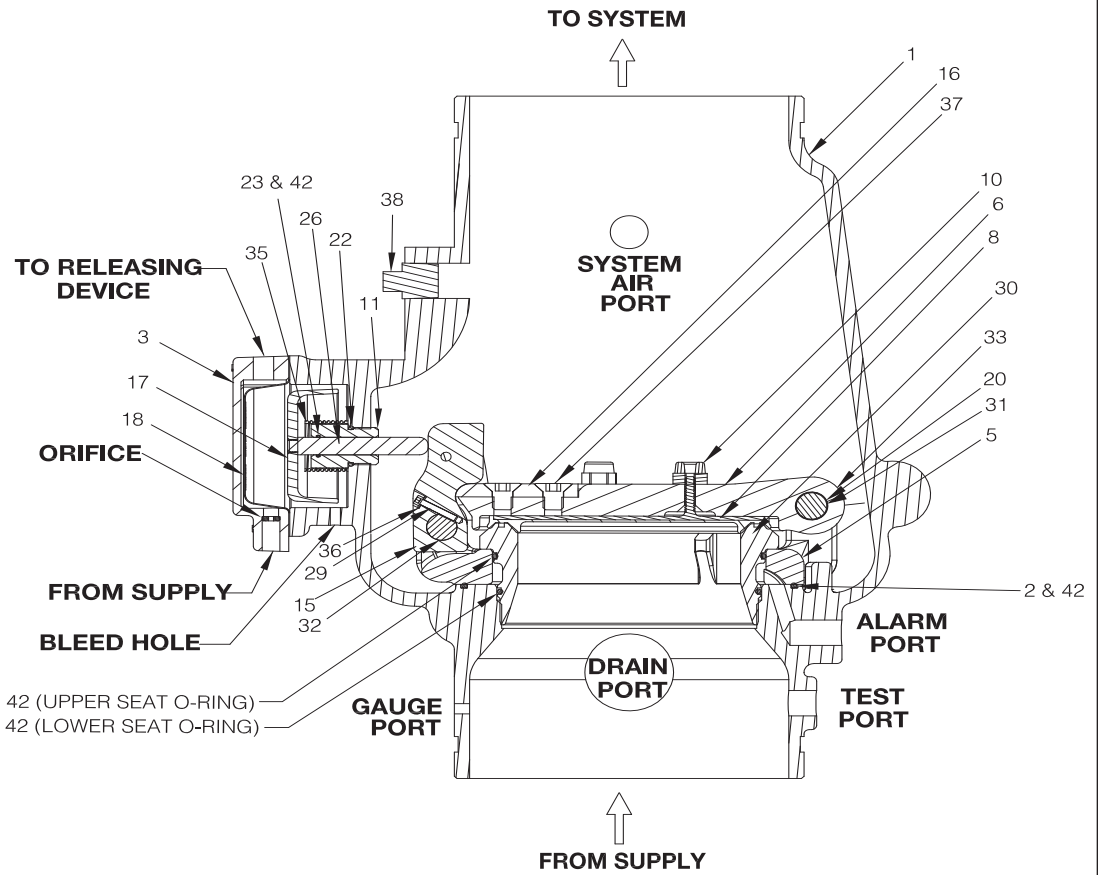
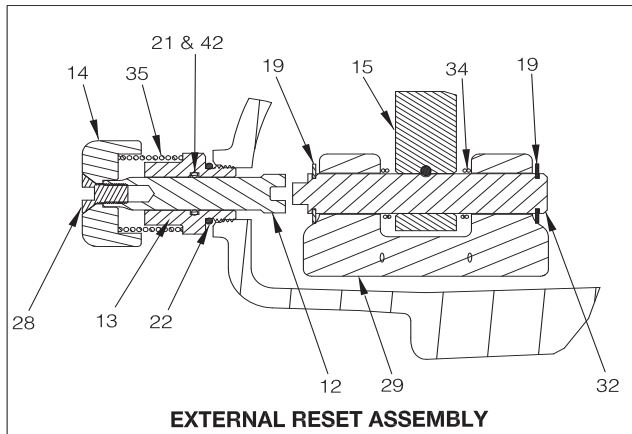
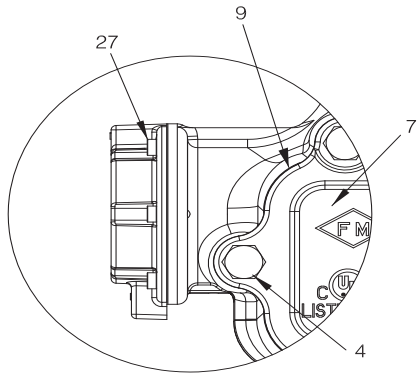

519FG12A

Fig. 7

**Model DDX (Screw-In Seat Configuration)
Deluge Valves Parts List (Refer to Fig. 7)**

Item No.	Part No.								Part Description	QTY.	Material	
	2" (50mm)	2½" (65mm)	76mm	3" (80mm)	4" (100mm)	165mm	6" (150mm)	8" (200mm)				
1	91006011	91006012	91006023	91006013	91006005	91006027	91006007	91006028	Valve Body Groove/Groove	1	Ductile Iron 65-45-12	
	N/A	N/A	N/A	N/A	91006045	N/A	91006067	N/A	Valve Body Flange/Groove			
	N/A	N/A	N/A	N/A	91006035	N/A	91006037	91006039	Valve Body Flange/Flange			
2	N/A	N/A	N/A	N/A	N/A	N/A	N/A	95406414	O-ring (Mounting Ring)	1	Buna-N	
3	71040416								Pushrod Cover Assembly	1	Ductile Iron 65-45-12 & Brass C360000	
4	91106123			N/A		N/A		N/A		Hex Bolt ½"-13 x 1¼"	6	Zinc Plated Steel
	N/A			95606107		N/A		N/A		Hex Bolt ½"-13 x 1½"	6	Zinc Plated Steel
	N/A			N/A		91106006		N/A		Hex Bolt 5/8"-11 x 1¾"	6	Zinc Plated Steel
	N/A			N/A		N/A		95606110		Hex Bolt 5/8"-11 x 2"	8	Zinc Plated Steel
5	91306013			91306014		91306016		91306018		Mounting Ring	1	Stainless Steel CF8 or CF8M
6	91916013			91916014		91916016		91916008		Clapper	1	Stainless Steel CF8 or CF8M
7	92116063			92116064		92116065		92116066		Access Cover	1	Ductile Iron 65-45-12
8	93416003			93416014		93416016		93416008		Seal Assembly	1	Stainless Steel 304 & EPDM
9	93706003			93706004		93706006		93706008		Access Cover Gasket	1	Buna-N or Neoprene
10	93722000			93722000		N/A		N/A		Bumpstop Assembly	1	Stainless Steel UNS S31600 & EPDM
	N/A			N/A		93722000		N/A			2	
	N/A			N/A		N/A		93722000			3	
11	93916006								Pushrod Guide	1	Acetal	
12	93916066								Reset Shaft	1	Brass UNS C36000	
13	94106066								Reset Housing	1	Brass UNS C36000	
14	94356006								Reset Knob	1	Aluminum 6061	
15	94506003			94506004		94506016		94506008		Lever	1	Stainless Steel UNS S17400
16	95006414			94006412		95006410		95006410		Striker	1	Aluminum Bronze C95400
17	95106006								Piston	1	Stainless Steel CF8M	
18	95276006								Diaphragm	1	EPDM & Polyester	
19	95306267			N/A		N/A		N/A		Retaining Ring, 3/8" Shaft, Lever Pin	2	Stainless Steel 15-7 or 17-7
	N/A			95306267		N/A		N/A		Retaining Ring, ½" Shaft, Lever Pin		
	N/A			N/A		95306269		N/A		Retaining Ring, 5/8" Shaft, Lever Pin		
	N/A			N/A		N/A		95316408		Retaining Ring, ¾" Shaft, Lever Pin		
20	95306268			N/A		N/A		N/A		Retaining Ring, 3/8" Shaft, Hinge Pin	2	Stainless Steel 15-7 or 17-7
	N/A			95306267		95306267		N/A		Retaining Ring, ½" Shaft, Hinge Pin		
	N/A			N/A		N/A		95316408		Retaining Ring, ¾" Shaft, Hinge Pin		
21	95406007								O-Ring, Reset Housing ID	1	Buna-N	
22	95406024								O-Ring, Reset Housing & Pushrod Guide OD	2	Buna-N	
23	95406407								O-Ring, Pushrod Guide ID	1	Buna-N	
24	95406410			95406409		95436126		95406413		O-Ring, Upper Seat	1	Buna-N
25	95406411			95406420		95446226		95406412		O-Ring, Lower Seat	1	Buna-N
26	95506006								Pushrod	1	Stainless Steel UNS S30300	
27	95606114								Socket Head Screw, ¼"-20 x 5/8"	6	Steel	
28	95606127								Flat Head Socket Cap Screw 3/8"-16 x ¾"	1	Steel	
29	95606133			N/A		N/A		N/A		Socket Head Screw #6-32 x ½"	1	Stainless Steel 18-8
	N/A			95606130		95606130		95606130		Socket Head Screw #10-32 x 1"		
30	96016003			96016014		96016016		96016008		Seat	1	Stainless Steel CF8M
31	96206003			N/A		N/A		N/A		Hinge Pin	1	Stainless Steel UNS S30400
	N/A			96216086		96216068		96206008				
32	96216003			N/A		N/A		N/A		Lever Pin	1	Stainless Steel UNS S17400
	N/A			96216044		96216047		96216008				
33	96310003			96906904		96906904		96310008		Clapper Spacer	2	Teflon or Acetal
34	96406003			N/A		N/A		N/A		Lever Spring	1	Stainless Steel UNS S30400
	N/A			96406004		96406005		96406008			1	Stainless Steel UNS S31600
35	96406906								Piston/Reset Spring	2	Stainless Steel UNS S31600	
36	96906112			N/A		N/A		N/A		Spring Lock Washer, #6	1	Stainless Steel 18-8
	N/A			96906111		96906111		96906111		Spring Lock Washer, #10		
37	95606140			N/A		N/A		N/A		Flat Head Socket Cap Screw ¼"-20 x ½"	2	Stainless Steel 18-8
	N/A			95606139		N/A		N/A		Flat Head Socket Cap Screw ¼"-20 x ½"		
	N/A			N/A		N/A		95606135		Flat Head Socket Cap Screw ½"-13 x ¾"		
38	98604402								Plug, ½" NPT	1	Steel	
39	94616921								Knob Caution Label (Not Shown)	1	Polystyrene	
40	91556922								Ball Chain, 1/8" (Not Shown) (Length is in Inches)	6	Nickel Plated Brass	
41	91556923								Clamping Link, Ball Chain (Not Shown)	1	Nickel Plated Brass	
42	699993406								O-Ring Grease, Duponttm Krytox® GPL-205	A/R	Krytox®	

**MODEL DDX DELUGE VALVE [4"(100MM), 6"(150MM) & 165 MM]
(DROP-IN SEAT CONFIGURATION)**

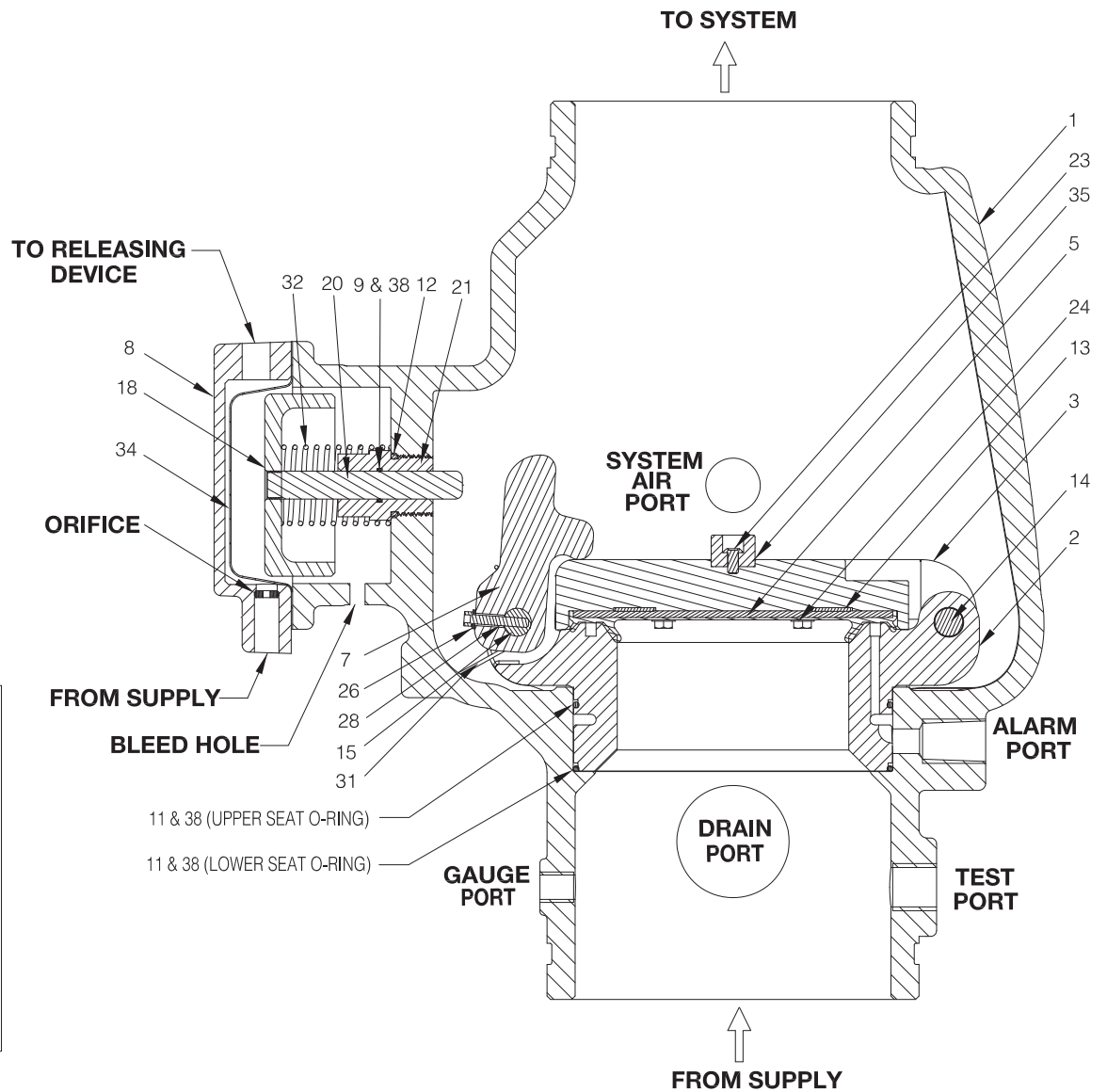
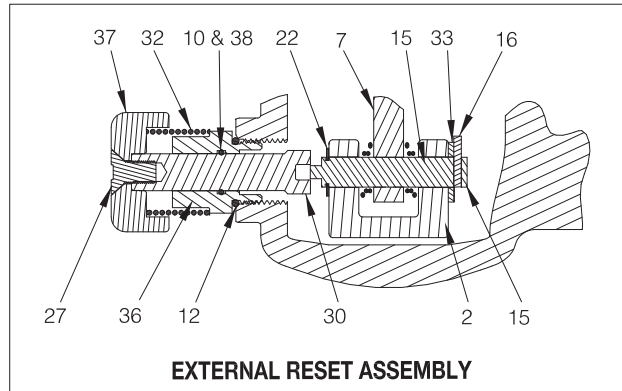
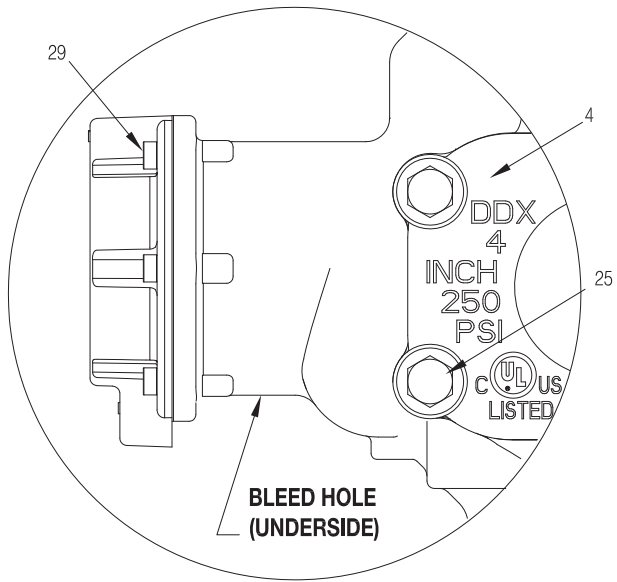

18.

519FG13A

Fig. 8

**Model DDX 4" (100mm), 165mm & 6" (150mm) (Drop-In Seat Configuration) Deluge Valves Parts List
(Refer to Fig. 13)**

Item No.	Part No.			Part Description	QTY.	Material
	4" (100mm)	165mm	6" (150mm)			
1	91006005	91006027	91006007	Valve Body	1	Ductile Iron 65-45-12
2	96016004	96016006		Seat	1	Brass UNS C86300
3	91916004	91916006		Clapper	1	Brass UNS C86300
4	92116064	92116065	92116066	Access Cover	1	Ductile Iron 65-45-12
5	93416004	93416006		Seal Assembly	1	Stainless Steel 304 & EPDM
6	93706004	93706006		Access Cover Gasket	1	Buna-N or Neoprene
7	94506004	94506006		Lever	1	Stainless Steel UNS S17400
8	71040416			Pushrod Cover Assembly	1	Ductile Iron 65-45-12
9	95406407			O-Ring, Pushrod Guide ID	1	Buna-N
10	95406007			O-Ring, Reset Housing ID	1	Buna-N
11	95406006	95406016		O-Ring, Upper Seat	2	Buna-N
				O-Ring, Lower Seat		Buna-N
12	95406024			O-Ring, Reset Housing OD	2	Buna-N
13	93706001	93706002		Clapper Gasket	1	Buna-N or Neoprene
14	96216086			Hinge Pin	1	Stainless Steel UNS S21800
15	96216046			Lever Pin	1	Stainless Steel UNS S44000
16	95606131			Threaded Stud, #10-32 x 3/4"	1	Stainless Steel 18-8
17	96216066			Locking Pin (not shown)	2	Stainless Steel UNS S44000
18	95106006			Piston	1	Stainless Steel CF8M
19	95200038			Socket Plug 3/8" - 18 NPT (not shown)	2	Steel
20	95506006			Pushrod	1	Stainless Steel UNS S30300
21	93916006			Pushrod Guide	1	Acetal
22	95306267			Retaining Ring, 1/2" Shaft	3	Stainless Steel 15-7 or 17-7
23	95606128			Button Head Screw #10-32 x 3/8"	1	
24	95606129			Hex Washer Head Screw #10-32 x 3/8"	4	Stainless Steel 18-8
25	95606107	N/A		Hex Cap Screw 1/2"-13 x 1 1/2"	6	Zinc Plated Steel
	N/A	91106006		Hex Cap Screw 5/8"-11 x 1 3/4"		
26	96906111			Spring Lock Washer, #10	1	Stainless Steel UNS S31600
27	95606127			Flat Head Socket Cap Screw 3/8"-16 x 3/4"	1	Steel
28	95606130			Socket Head Screw #10-32 x 1"	1	Stainless Steel UNS S31600
29	95606136			Socket Head Screw, 1/4"-20 x 5/8"	6	Steel
30	93916066			Reset Shaft	1	Brass UNS C36000
31	96406004			Lever Spring	1	Stainless Steel UNS S30400
32	96406906			Piston/ Reset Spring	2	Stainless Steel UNS S31600
33	96906904			Clapper Spacer	3	Teflon
34	95276006			Diaphragm	1	EPDM & Polyester
35	92306006			Bumper Disc	1	SBR Rubber
36	94106066			Reset Housing	1	Brass UNS C36000
37	94356006			Reset Knob	1	Aluminum 6061
38	6999993406			O-Ring Grease, Dupont™ Krytox® GPL-205	A/R	Krytox®
39	94616921			Knob Caution Label (Not Shown)	1	Polystyrene
40	91556922			Ball Chain, 1/8" (Not Shown) (Length is in Inches)	6	Nickel Plated Brass
41	91556923			Clamping Link, Ball Chain (Not Shown)	1	

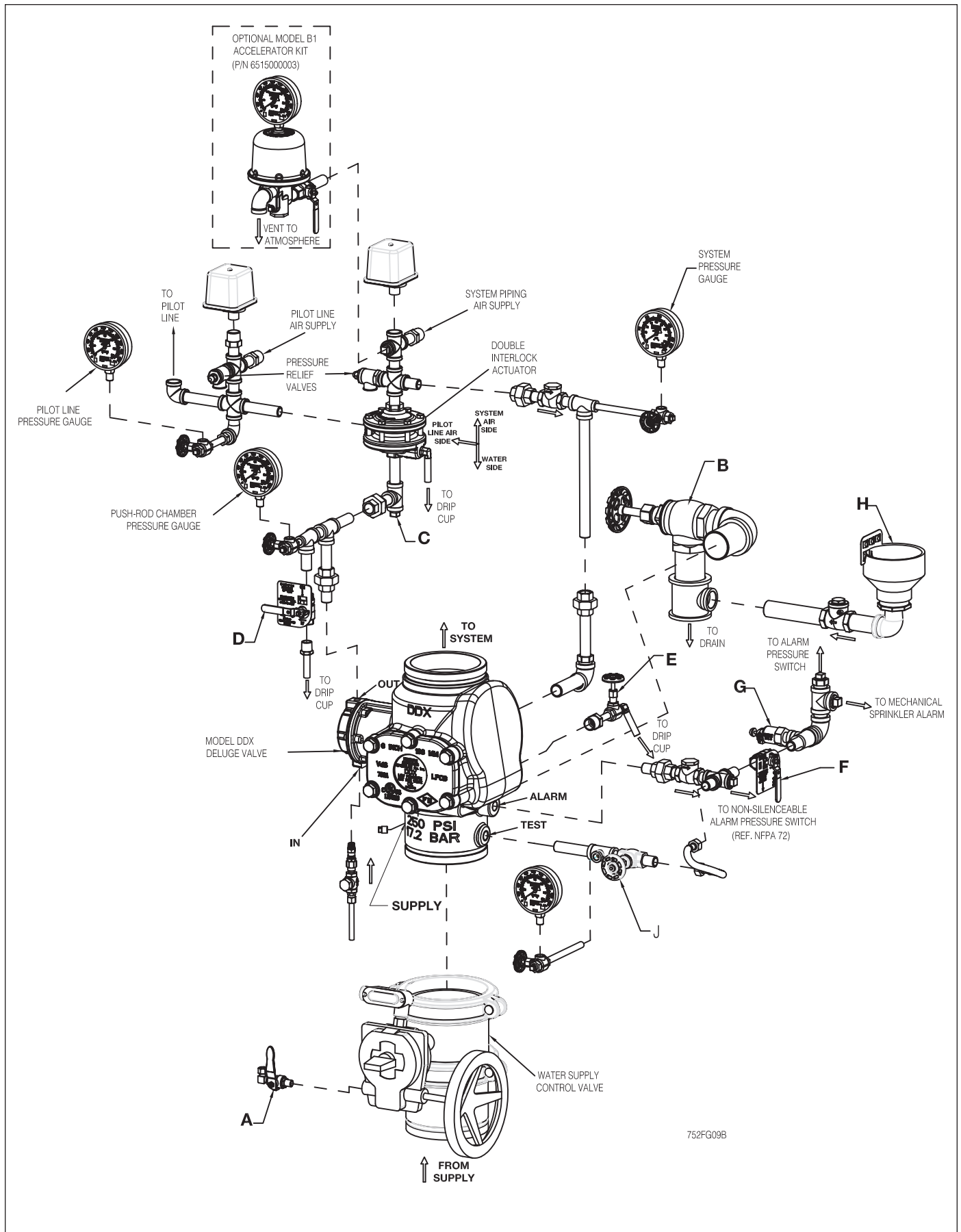

752FG09B

Fig. 9

flow to the electric sprinkler alarm switch and to the mechanical sprinkler alarm (water motor). After testing, close this valve securely. Push in on the plunger of ball drip valve G (Fig. 9) until all of the water has drained from the alarm line.

8. **Operational test** — Open the Model B Manual Emergency Station, valve D (Fig. 9). **Note:** An operational test will cause the Deluge Valve to open and flow water into the sprinkler system.
9. Secure Model B Manual Emergency Station, valve D (Fig. 9), in the OFF position with a nylon tie (#59, Fig. 2 or #59, Fig. 3) after the Deluge Valve is reset see Fig. 5.

Testing Detection System Without Operating Deluge Valve

Refer to Figs. 2, 3 & 9.

1. Close the valve controlling water supply to Deluge Valve and open the main drain valve B.
2. Verify that valve A is open, allowing water to enter the push rod chamber.
3. Close off the air/nitrogen supply to the sprinkler system.
4. Decrease pneumatic pressure in the system by opening the 1/4" globe valve, valve E. Once the pressure has been depleted, remove the 1/4" plug (#60, Fig. 2 or #30, Fig. 3) in the 3-way valve (#73, Fig. 2 or #73, Fig. 3) below the pilot line pressure gauge (see Fig. 9). Using the 3-way valve below the pilot line gauge (see Fig. 9), bleed the pressure off the pilot line, until the Model LPDI Double Interlock Actuator operates. This will be indicated by a sudden drop of water pressure on the pushrod chamber pressure gauge (see Fig. 9). This operation of the Actuator will result in a sudden drop of water pressure in the push rod chamber.
5. Proceed according to the directions listed in the "Resetting the Type PL Double Interlock Preaction System" section of this bulletin for resetting the Deluge Valve.

Draining Excess/Condensate Water From System

Refer to Fig. 9

1. Close the main valve controlling water supply to Deluge Valve. Also close valve A and open main drain valve B.
2. Open condensate drain valve E until all water has drained. Close valve E. **Note:** Be sure not to keep valve E open for an extended period of time because that will cause enough system air to bleed off of the system thereby causing an undesirable activation of a trouble-annunciating device.
3. Close main drain valve B. If system contains pressurized air, allow air pressure to come back up to specification. Open valve A first, and then open the main valve controlling the water supply to the Deluge Valve.

Maintenance Procedures - Model DDX Deluge Valve

Refer to Figs. 2, 3, 7, 8, & 9.

1. **Mechanical sprinkler alarm (water motor—not shown) not operating:** This is most likely caused by a clogged screen in the strainer of the water motor. Proceed as follows: Remove plug from the strainer. Remove and clean the screen. Replace the screen and the plug, and then tighten securely (Ref. Bulletin 613).
2. **Leakage out of the ball drip valve E (Fig. 9).**
 - a. **Water leakage due to water column in deluge**

systems:

This condition can be caused by leakage past the system side of the Model DDX Deluge Valve's seal assembly (#8, Fig. 7 or #5, Fig. 8). Be sure that this surface is free of any type of debris. To eliminate leakage due to water column in a deluge system, refer to the section in this bulletin marked "Draining Excess/Condensate Water From System". If the problem continues proceed to the following section.

b. Leakage, air or water from the ball drip valve, E (Fig. 9):

If system air is leaking out the ball drip valve, the problem is either damage to the airside of the Model DDX Deluge Valve's seal assembly (#8, Fig. 7 or #5, Fig. 8), seat (#29, Fig. 7 or #2, Fig. 8), the upper seat o-ring (#23, Fig. 7 or #11, Fig. 8) or, on the 8" (200 mm) valve size only, the mounting ring o-ring (#2, Fig. 7). If supply water is leaking out the ball drip valve, the problem could be caused by damage to the Model DDX Deluge Valve's seal assembly (#8, Fig. 7 or #5, Fig. 8), seat (#29, Fig. 7 or #2, Fig. 8), or lower seat O-ring (#24, Fig. 7 or #11, Fig. 8). The following section provides instructions to correct both conditions:

- A) Shut down the valve controlling the water supply to the Deluge Valve and open the 1/4" main drain valve on the 2" (50mm), 2 1/2" (65mm), 76mm and 3" (80mm) valve sizes or the 2" main drain valve on the 4" (100mm), 165mm, 6" (150mm) and 8" (200mm) valve sizes, valve B (Fig. 9). Open the water column drain valve E (Fig. 9). Close the pushrod chamber supply valve A (Fig. 9) and open the Model B Manual Emergency Station, valve D (Fig. 9).
- B) Remove the Deluge Valve's front (handhold) cover (#7, Fig. 7 or #4, Fig. 8) and inspect the seat (#29, Fig. 7 or #2, Fig. 8), clapper (#6, Fig. 7 or #3, Fig. 8), and seal assembly (#8, Fig. 7 or #5, Fig. 8) for damage. If inspection indicates damage to the seal assembly (#8, Fig. 7 or #5, Fig. 8), replace as follows:

For Valve Sizes: 2" (50mm), 2 1/2" (65mm), 76mm, 3" (80mm), 8" (200mm) and 4" (100mm), 6" (150mm) & 165mm with Screw-In Seat only, Refer to Fig. 2, Fig. 3 & Fig. 7:

Remove the bumpstop nuts (#10, Fig. 7) and remove the seal assembly (#8, Fig. 7). Install a new seal assembly (#8, Fig. 7) and thread the bumpstop nuts (#10, Fig. 7) onto the threaded studs of the seal assembly (#8, Fig. 7) and tighten finger tight plus 1/4 to 1/2 turn. If inspection indicates damage to the clapper (#6, Fig. 7) only, then the clapper subassembly can be removed as follows:

At the rear of the valve, disconnect the water column drain trim section starting with the elbow connector (#22, Fig. 2 or #21, Fig. 3). Then remove the 1/4" globe valve (#34, Fig. 2 or #33, Fig. 3), followed by the 3/4"x1/4" reducing bushing (#56, Fig. 2 or #56, Fig. 3). Remove the retaining ring (con-

condensate drain side for 2" (50mm), 2½" (65mm), 3" (80mm), 76mm and 8" (200mm) valve sizes or hand hole cover side for 4" (100mm), 6" (150mm) and 165mm valve sizes) from the clapper hinge pin (#19, Fig. 7) and push this pin through the hand hole opening for 2" (50mm), 2½" (65mm), 3" (80mm), 76mm and 8" (200mm) valve sizes or condensate drain port side for 4" (100mm), 6" (150mm) and 165mm valve sizes and remove the clapper subassembly. Replace the seal assembly as described previously. Inspect the clapper (#6, Fig. 7) visually before reinstalling. Reinstall in the reverse order making sure the clapper spacers are in their proper position. If the seat (#29, Fig. 7) is damaged or it is suspected that the leakage is through the lower O-ring (#24, Fig. 7), the seat-clapper subassembly is easily removed as a unit as follows:

Using Reliable P/N 6881603000 Seat Wrench for 2" (50mm), 2½" (65mm), 76mm and 3" (80mm) valve sizes, Reliable P/N 6881604000 for 4" (100mm) valve size, Reliable P/N 6881606000 for the 6" (150mm) and 165mm valve sizes or Reliable P/N 6881608000 Seat Wrench for 8" (200mm) valve size, remove the seat by unscrewing. This will loosen the seat-clapper-mounting ring subassembly. Reach into the valve and grasp the seat and remove it from the valve. Then remove the clapper-mounting ring subassembly from the valve. Visually examine all components of the seat-clapper-mounting ring subassembly replacing any component that appears damaged. New O-rings (#23 & #24, Fig. 7 and #2, Fig. 7 for the 8" valve size only) should always be used for reassembly.

For Valve Sizes: 4" (100mm), 165mm, 6" (150mm) with Drop-In Seat Configuration only, Refer to Fig. 3 and Fig. 8:

At the rear of the valve, disconnect the water column drain trim section starting with the elbow connector (#21, Fig. 3). Then remove the ¼" globe valve (#33, Fig. 3), followed by the ¾"x¼" reducing bushing (#56, Fig. 3). Remove the retaining ring (hand hole cover side) from the clapper hinge pin (#14, Fig. 8) and push this pin through the condensate drain port and remove the clapper subassembly. Remove the four retaining screws (#24, Fig. 8) holding the seal faceplate assembly (#5, Fig. 8). Inspect the clapper (#3, Fig. 8) visually before installing. Apply a small amount of silicone based lubricant to the four retaining screws. Install a new seal faceplate assembly. Torque the retaining screws to approximately 40 inch-pounds and reassemble. If the seat (#2, Fig. 8) is damaged or it is suspected that the leakage is through the lower o-ring (#11, Fig. 8), the seat-clapper subassembly is easily removed as a unit as follows:

Using a 5/16" Allen wrench, remove the two 3/8" NPT pipe plugs (#19, (not shown) Fig. 8) locat-

ed on the side chamber side of the Model DDX deluge valve. The seat-clapper subassembly is retained by two locking pins (#17, (not shown) Fig. 8). The centers of these pins have a ¼"-20 threaded hole. Remove the two locking pins by engaging them with a ¼"-20 screw and pulling them out (the two locking pins are not externally threaded, so turning them with the attached ¼"-20 screw or threaded rod is not recommended. A proven method is to use ¼"-20 threaded rod with a locknut on the unassembled end. Grab hold of the locknut with a pliers or vise-grips and tap the pliers or vise-grips in the direction away from the Deluge Valve. Doing so should pull the locking pins out of the Deluge Valve. With the clapper (#3, Fig. 8) in the closed position (not latched), dislodge the clapper-seat subassembly from the valve body by inserting two slotted screwdrivers under the lever and clapper mounting ears and pry up until the clapper-seat subassembly is free from its bore. Reach into the valve and grasp the clapper-seat subassembly from the sides. Making sure the clapper is in the closed position (see Fig. 1), lift up and rotate the clapper-seat sub assembly clockwise 90 degrees so that the lever side of the assembly is facing up towards the outlet of the deluge valve. Next, rotate the clapper-seat sub assembly 90 degrees about the centerline of the valve so that the clapper is facing the hand hole opening and the lever is still facing the outlet of the deluge valve.. Then rotate the clapper-seat sub assembly 90 degrees, so that the clapper is now facing the outlet of the deluge valve and the lever is now facing the back of the valve. Pull the clapper-seat sub assembly out through the hand hole opening by the hinge pin side. Rotating the seat-clapper subassembly up as it is being removed will help it slide out more easily since the lever will prohibit it from sliding straight out. Visually examine all components of the clapper-seat subassembly replacing any component that appears damaged. New o-rings (#11, Fig. 8) should always be used for reassembly.

Reassembly:

For Valve Sizes: 2" (50mm), 2½" (65mm), 76mm, 3" (80mm), 8" (200mm) and 4" (100mm), 6" (150mm) & 165mm with Screw-In Seat only, Refer to Fig. 7:

Clean the bore of the valve body. Lubricate the bore with O-ring grease. Lubricate and install the O-rings (#23 & #24, Fig. 7) onto the seat Lubricate and install the mounting ring o-ring (#2, Fig. 7) into the body (8" (200mm) valve size only). Insert the clapper-mounting ring subassembly into the handhold opening of the Deluge Valve using caution to not damage or dislodge the mounting ring o-ring (#2, Fig. 7)(8" (200mm) valve size only). Align the mounting ring so that the Lever (#15, Fig. 7) is near the pushrod (#25, Fig. 7) and the mounting ring (#5, Fig. 7) "ears" are between the tabs of

the valve body (#1, Fig. 11). Insert the seat (#29, Fig. 7) into the valve body (#1, Fig. 7) and through the clapper-mounting ring subassembly. Start to tread the seat (#29, Fig. 7) into the body by hand, then tighten the seat (#29, Fig. 8) with Reliable P/N 6881603000 Seat Wrench for 2" (50mm), 2½" (65mm), 76mm and 3" (80mm) valve sizes, Reliable P/N 6881604000 for 4" (100mm) valve size, Reliable P/N 6881606000 for the 6" (150mm) and 165mm valve sizes or Reliable P/N 6881608000 Seat Wrench for 8" (200mm) valve size until it bottoms out on the mounting ring (#5, Fig. 7). Verify that the seat-clapper-mounting ring subassembly is in the fully down position between the tabs of the body, and check to see that the lever (#15, Fig. 7) lines up with the push rod (#25, Fig. 7). Loosen and reassemble if necessary. Reassemble the handhold cover (#7, Fig. 7) and set up the Model DDX Deluge Valve as per the section "Resetting Model DDX Type PL Double Interlock Preaction Systems."

For Valve Sizes: 4" (100mm), 165mm, 6" (150mm) with Drop-In Seat Configuration only, Refer to Fig. 8:

It is likely that the lower seat o-ring (#11, Fig. 8) has remained at the bottom of the Deluge Valve body's bore. Discard this o-ring and clean the bore. Lubricate the bore with o-ring grease and place the lower o-ring on the step at the bottom of the bore, verifying that it is in full contact with the bore. Lubricate the bottom step and upper o-ring (#11, Fig. 8) of the refurbished clapper-seat subassembly. Insert the clapper-seat sub assembly into the hand hole opening, lever (#7, Fig. 8) first and rotating the clapper-seat subassembly until the lever faces the outlet of the deluge valve. Next rotate the clapper-seat subassembly 90 degrees about the center axis of the valve until the bottom of the clapper-seat sub assembly faces the pushrod (#20, Fig. 8). Then rotate the clapper-seat subassembly 90 degrees counterclockwise so that the clapper (#3, Fig. 8) is facing the outlet of the deluge valve and the lever (#7, Fig. 8) is facing the pushrod (#20, Fig. 8). Once the clapper seat subassembly is in this position simply slide the assembly into the bore of the valve, making sure it is straight to avoid binding of the seat in the bore. Slightly twisting the assembly will assist in getting the clapper-seat subassembly properly seated. Once it is verified that the clapper-seat sub assembly is in the fully down position and the lever (#7, Fig. 8) is aligned with the pushrod (#20, Fig. 8), clean and lubricate the two locking pins (#17, (not shown) Fig. 8) with o-ring lubricant. Slide the two locking pins into the deluge valve body to lock the seat in place. Slightly twisting and pressing down on the clapper-seat subassembly will help the pins to slide in more easily. Then reinstall the 3/8" NPT pipe plugs (#19, (not shown) Fig. 8). Re-

assemble the hand hole cover (#4, Fig. 8) and set up the Model DDX Deluge Valve as per the section "Resetting Model DDX Type PL Double Interlock Preaction Systems".

3. Leakage out of the push rod chamber vent hole:

A small bleed hole is located on the underside of the push rod chamber (see Fig. 7 or Fig. 8). If there is air or water leakage coming out of this hole, do the following:

- a) Shut down the valve controlling water supply to the Deluge Valve. Relieve the inlet pressure by opening the 1¼" main drain valve on the 2" (50mm), 2½" (65mm), 76mm and 3" (80mm) valve sizes or the 2" main drain valve on the 4" (100mm), 165mm, 6" (150mm) and 8" (200mm) valve sizes, valve B (Fig. 9). Close the valve A (Fig. 9) that supplies water to the push rod chamber, and open the Model B Manual Emergency Station, valve D (Fig. 9).
- b) Remove the trim at the unions nearest to the push rod chamber cover (#3, Fig. 7 or #8, Fig. 8).
- c) Take the push rod chamber cover (#3, Fig. 7 or #8, Fig. 8) off by removing the six retaining screws (#26, Fig. 7 or #29, Fig. 8).

CONDITION ONE (Water coming out of the bleed hole):

Water coming out of the bleed hole is caused by a leaking diaphragm (#18, Fig. 7 or #34, Fig. 8). Visually inspect the push rod chamber cover (#3, Fig. 7 or #8, Fig. 8) and piston (#17, Fig. 7 or #18, Fig. 8) to determine what could have damaged the diaphragm and correct. Install a new diaphragm. **NOTE: The diaphragm has two different surfaces: it is not bi-directional. It will fail if installed backwards!** Roll the diaphragm so that the smooth surface (the pressure side) conforms to the inside of the push rod chamber cover and reassemble the six retaining screws (#26, Fig. 7 or #29, Fig. 8) with an installation torque of 15 foot-pounds. Set up the Model DDX Deluge Valve as per the section "Resetting Model DDX Type PL Double Interlock Preaction Systems."

CONDITION TWO (System Air coming out of the bleed hole):

System air coming out of the bleed hole is caused by a defective O-ring assembled to the push rod guide (#11, Fig. 7 or #9, Fig. 8). Remove the piston-push rod subassembly, push rod spring (#34, Fig. 7 or #32, Fig. 8), and push rod guide (#11, Fig. 7 or #21, Fig. 8). Verify by hand turning, that the push rod cannot be unscrewed from the piston. Replace all O-rings and the push rod guide (#21, #22 & #11, Fig. 7 or #9, #12 & #21, Fig. 8). The correct installation torque for the pushrod guide is 35 inch-pounds. **CAUTION: Do not over tighten the push rod guide.** Reassemble the components that were initially removed. Re-install the diaphragm (#18, Fig. 7 or #34, Fig. 8) if it appears to be in good shape, otherwise, replace it also. **NOTE: The diaphragm has two different surfaces: it is not bi-directional. It will fail if installed backwards!** Roll the diaphragm so that the smooth surface (the pressure side) conforms to the inside of the push rod chamber

MODEL LPDI DOUBLE INTERLOCK ACTUATOR

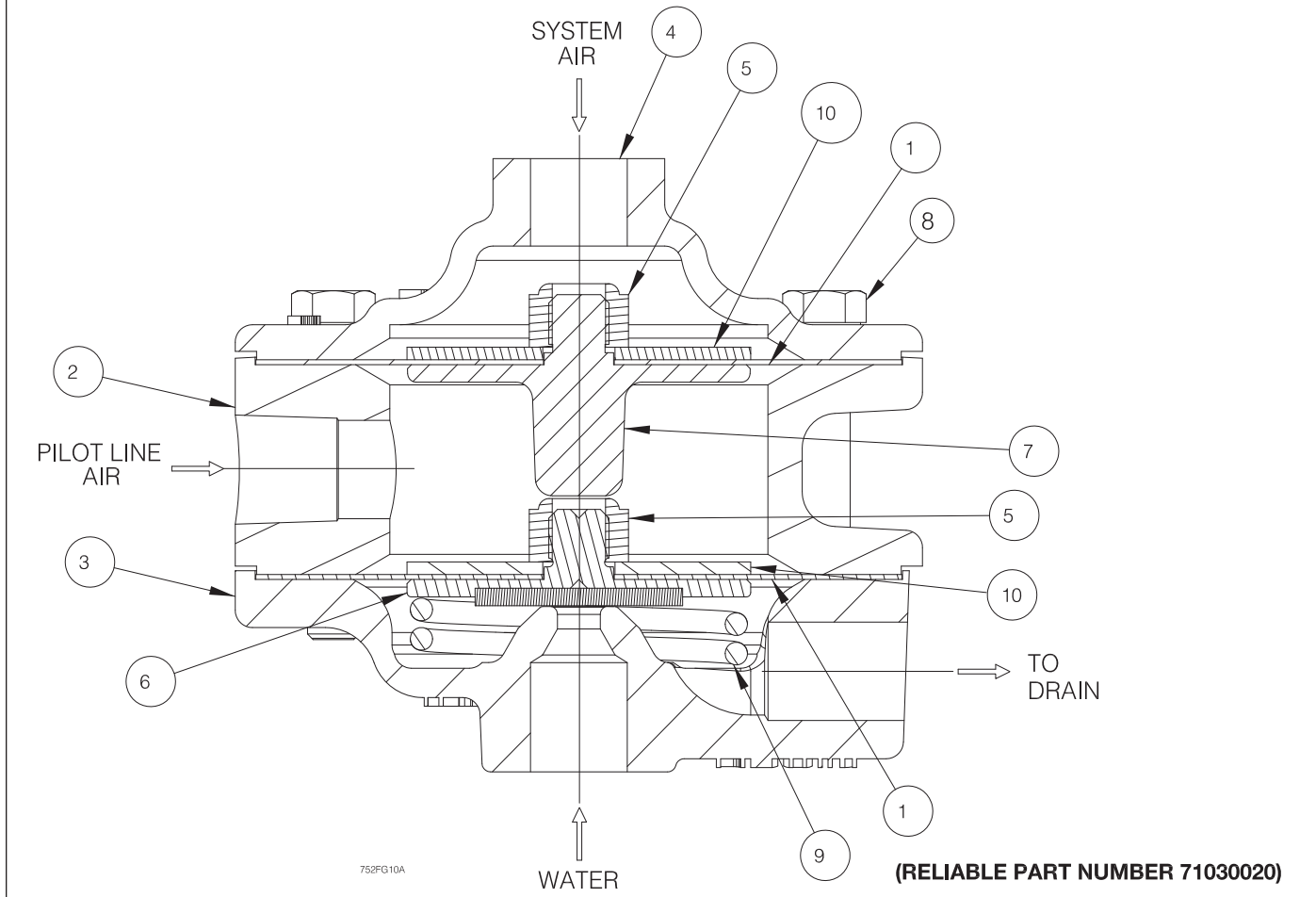

Fig. 10

cover and reassemble the six retaining screws (#26, Fig. 7 or #29, Fig. 8) with an installation torque of 15 foot-pounds. Set up the Model DDX Deluge Valve as per the section "Resetting Model DDX Type PL Double Interlock Preaction Systems."

Ordering Information

Specify:

Model LP Dry Pilot Line Actuator Parts List P/N 71030010

Item No.	Part No.	Description	Qty. Required
1	92206311	Diaphragm	2
2	94106943	Middle Housing	1
3	94126937	Upper Housing	1
4	94126938	Lower Housing	1
5	94906406	Facing Plate Nut	2
6	95106912	Facing Plate Assembly	1
7	95106916	Upper Facing Plate	1
8	95606305	Bolt	6
9	96406902	Compression Spring	1
10	96906311	Diaphragm Washer	2

Maintenance – Model LP Dry Pilot Line Actuator

Refer to Figs. 9 & 10

If water constantly flows through the Model LP Dry Pilot Line Actuator and into the drain, there is a leak in the seal of the Actuator's seat.

1. Close the main valve controlling water supply (Fig. 9) to the Dry Pipe Valve and close off the air/nitrogen supply to the sprinkler system and pilot line. Close valve A (Fig. 9).
2. Drop pressure in the system by opening the 1/4" globe valve, valve E (Fig. 9) and remove the 1/4" plug from the 3-way valve below the pilot line pressure gauge (see Fig. 9). Using the 3-way valve, bleed the air from the pilot line, and remove the Actuator from the system.
3. Remove all six bolts (#8, Fig. 10) holding the Actuator together. Clean or replace the facing plate assembly (#6, Fig. 10) and diaphragms (#1, Fig. 10).
4. Reassemble the Actuator, using a torque of 8 ft-lbs on the facing plate nut (#5, Fig. 10) and 12 ft-lbs on the six bolts (#8, Fig. 10). Use a cross-tightening pattern. Reinstall the Actuator. Set up the Model DDX Deluge Valve as per the section "Resetting Model DDX Deluge Valve System".

• **Valve Model & Size** —

Valve Part Numbers			
Valve Size & End Connection	Flange Type	Color	Reliable Part Number
2" (50mm) Grv/Grv	N/A	Black	6103022000
		Red	6103022001
2½" (65mm) Grv/Grv	N/A	Black	6103022500
		Red	6103022501
3" (80mm) Grv/Grv	N/A	Black	6103030000
		Red	6103030001
76mm Grv/Grv	N/A	Red	6103027600
4" (100mm) Grv/Grv	N/A	Black	6103040026
		Red	6103040030
4" (100mm) Flg/Grv	ASME Class 150	Black	6103040044
	ASME Class 150	Red	6103040046
	ISO PN16	Red	6103040048
4" (100mm) Flg/Flg	ASME Class 150	Black	6103040045
	ASME Class 150	Red	6103040047
	ISO PN16	Red	6103040049
6" (168mm) Grv/Grv	N/A	Black	6103060024
		Red	6103060030
6" (168mm) Flg/Grv	ASME Class 150	Black	6103060045
	ASME Class 150	Red	6103060048
	ISO PN16	Red	6103060049
6" (168mm) Flg/Flg	ASME Class 150	Black	6103060046
	ASME Class 150	Red	6103060047
	ISO PN16	Red	6103060050
165mm Grv/Grv	N/A	Red	6103060028
165mm Flg/Grv	ASME Class 150	Red	6103060051
	ISO PN16	Red	6103060052
8" (200mm) Grv/Grv	N/A	Black	6103080001
		Red	6103080003
8" (200mm) Flg/Flg	ASME Class 150	Black	6103080016
	ASME Class 150	Red	6103080018
	ISO PN16	Red	6103080020

- **Trim** — Double Interlock Type PL Preaction Trim. Each trim set is available in individual parts, in time-saving, segmentally assembled kit forms, or fully assembled to the Model DDX Deluge Valve with or without a control valve).

Note: For metric installations, a 1¼" NPT x R1¼. ISO 7/1 x Close Nipple (Reliable P/N 98543403) or a 2" NPT x R2. ISO 7/1 x Close Nipple (Reliable P/N 98543401) is sold separately as an adapter for the single drain outlet of the trims.

- **Additional equipment** — (Refer to Fig. 9 & Fig. 11).

UL/FM
Approved

Trim Part Numbers						
Valve Size & End Connection	Flange Type	Color	Trim Configurations			
			Individual Parts (Model DDX Valve Sold Seperately)	Segmentally Assembled (Model DDX Valve Sold Seperately)	Fully Assembled to Model DDX Valve w/o Control Valve	Fully Assembled to Model DDX Valve w/ Control Valve
2" (50mm) Grv/Grv	N/A	Black	6505040553	6505040554	6505020101	6505020100
		Red			6505A20101	6505A20100
2½" (65mm) Grv/Grv	N/A	Black			6505022601	6505022600
		Red			6505A22601	6505A22600
3" (80mm) Grv/Grv	N/A	Black			6505030101	6505030100
		Red			6505A30101	6505A30100
76mm Grv/Grv	N/A	Red			6505A27701	N/A
4" (100mm) Grv/Grv	N/A	Black			6505040301	6505040300
		Red			6505A40301	6505A40300
4" (100mm) Flg/Grv	ASME Class 150	Black			6505043301	N/A
	ASME Class 150	Red	6505A43301			
	ISO PN16	Red	6505A44301			
4" (100mm) Flg/Flg	ASME Class 150	Black	6505047301	N/A		
	ASME Class 150	Red	6505A47301			
	ISO PN16	Red	6505A48301			
6" (168mm) Grv/Grv	N/A	Black	6505060301	6505060300		
		Red	6505A60301	6505A60300		
6" (168mm) Flg/Grv	ASME Class 150	Black	6505063301	N/A		
	ASME Class 150	Red	6505A63301			
	ISO PN16	Red	6505A64301			
6" (168mm) Flg/Flg	ASME Class 150	Black	6505067301	N/A		
	ASME Class 150	Red	6505A67301			
	ISO PN16	Red	6505A68301			
165mm Grv/Grv	N/A	Red	6505A65301	N/A		
165mm Flg/Grv	ASME Class 150	Red	6505A66301	N/A		
	ISO PN16	Red	6505A69301			
8" (200mm) Grv/Grv	N/A	Black	6505080301	6505080300		
		Red	6505A80301	6505A80300		
8" (200mm) Flg/Flg	ASME Class 150	Black	6505087301	N/A		
	ASME Class 150	Red	6505A87301			
	ISO PN16	Red	6505A88301			

Item No.	Component Part	Mfgr.	Description	Technical Bulletin
1	Water Supply Control Valve	Select	OS&Y	-
			Butterfly	-
	Tamper Switch (Optional) for OS&Y Valve	C	Model OS&Y2	Potter 5400928
			Tamper Switch (Optional) for Butterfly Valve	Model P1BV2
2	Deluge Valve	B	Model DDX	Reliable 518/519
3	Double Interlock Trim Kit (Type PL)	B	Refer to Parts List in this Bulletin	Reliable 752
4	Waterflow Alarm Pressure Switch	C	Model PS10-2 (DPDT cULus, FM)	Potter 5400928
			Model PS10-2 (DPDT VdS)	
5	Mechanical Alarm (Optional)	B	Model C	Reliable 612 / 613
6	Low Air Pressure Switch	C	Model PS25-2 (DPDT cULus, FM)	Potter 5401564
			Model PS25-2 (DPDT VdS)	
7	Alarm Annunciator	A	Model SSM24-8 24 VDC / Polarized Bell	-
			Model SSM24-10 24 VDC / Polarized Bell	
			Model MA24-D 24 VDC / Polarized Sounder	
			Model MASS24LO 24 VDC / Polarized Sounder Strobe	
8	Trouble Annunciator	A	Model SSM24-6 24 VDC / Polarized Bell	-
			Model MA24-D 24 VDC / Polarized Sounder	
9	Pilot Line Detectors	B	F1-FTR Fixed Temperature	Reliable 180
10	Sprinklers	B	Closed Type	Reliable 110, 117, 131, 136, etc.
11	*Air Compressor	E	Per NFPA 13 Requirements	Gast F-30
12	Pressure Maintenance Device	B	Model A-2 or Model B-1	Reliable 254
13	* Accelerator Kit	B	Model B1	Reliable 323
14	Nitrogen Regulating Device	B	Regulator with Optional Low Air Pressure Switch	Reliable 254

* If the optional Model B1 Accelerator is used, a tank-mounted air compressor and an A-2 pressure maintenance device must be provided. Additionally the use of a tank-mounted air compressor helps to eliminate on/off compressor cycling that may occur as a result of small leakage in the system piping as well as due to ambient temperature changes in the system piping.

System Equipment Manufacturers

- (A) Notifier
- (B) Reliable Automatic Sprinkler Co., Inc.
- (C) Potter Electric Signal Company
- (D) ---
- (E) Gast Mfg, Inc.

TYPE PL DOUBLE INTERLOCK PREACTION SYSTEM COMPONENTS

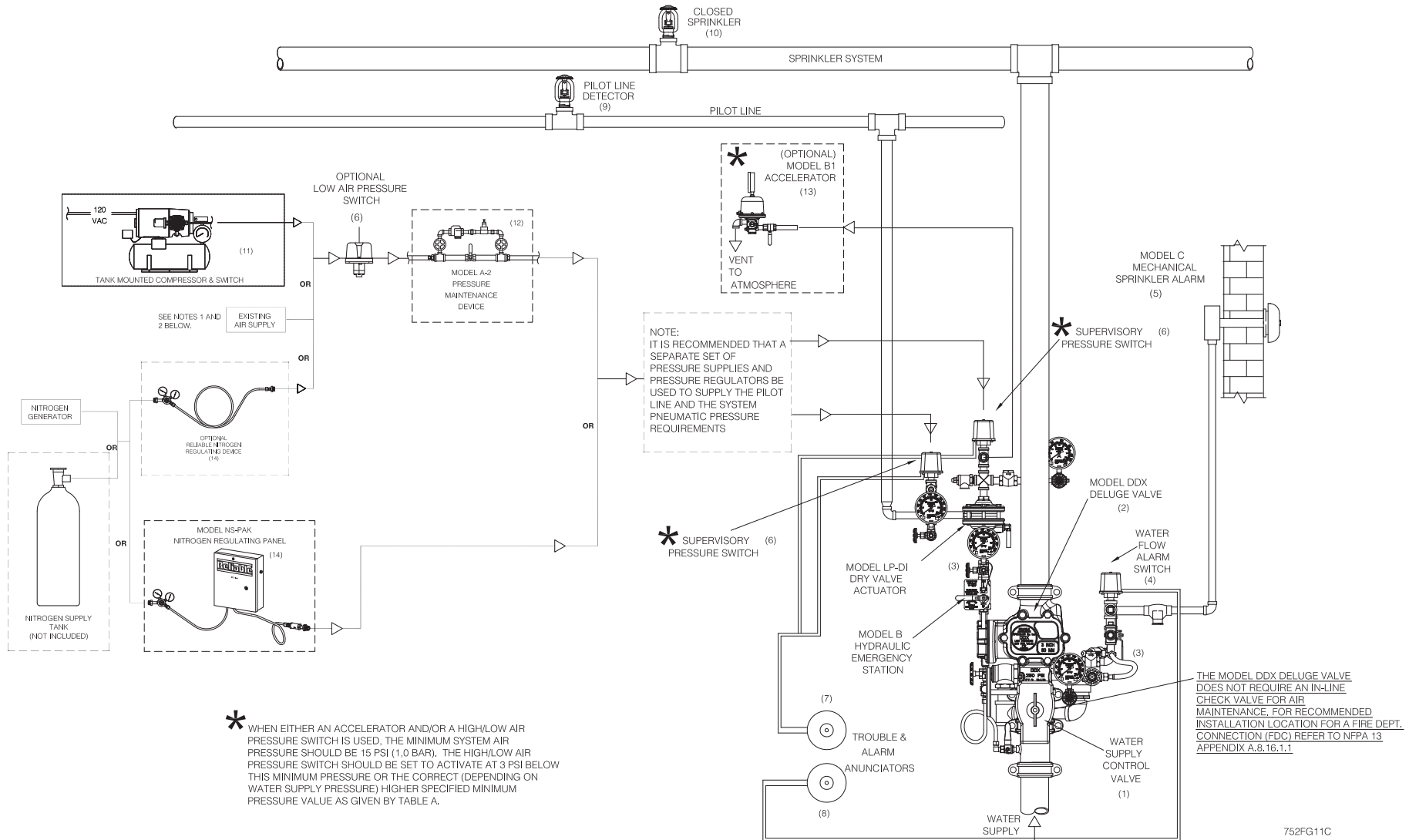

NOTE 1: THIS DRAWING DEPICTS THE RECOMMENDED PNEUMATIC SUPPLY SYSTEMS THAT WILL OPTIMIZE SYSTEM PERFORMANCE, BUT IS NOT INTENDED TO PROHIBIT ANY SUPPLY ARRANGEMENT(S) CURRENTLY MEETING THE REQUIREMENTS OF NFPA 13.

NOTE 2: WHEN THE OPTIONAL MODEL B1 ACCELERATOR IS USED, A TANK MOUNTED COMPRESSOR OR NITROGEN TANK WITH THE MODEL A-2 PRESSURE MAINTENANCE DEVICE IS REQUIRED.

752FG11C

Fig. 11

Nominal Pipe Size	Installation Dimensions in Inches (mm)																		
	A	B	C	D*	D**	D**	D***	E	F	G	H	J	K	L	M	N	P	Q	R
2" (50 mm)	8 (203)	7 (178)	9½ (241)	12½ (318)	21¼ (540)	21¼ (540)	N/A	25 (635)	38¼ (972)	30 (762)	6 (152)	9¼ (235)	4¼ (108)	5½ (140)	11 (279)	3 (76)	4½ (114)	6 (152)	20¼ (514)
2½" (65 mm), 3" (80 mm) & 76 mm	8 (203)	7 (178)	9½ (241)	12½ (318)	22 (559)	22 (559)	N/A	25 (635)	38¼ (972)	30 (762)	6 (152)	9¼ (235)	4¼ (108)	5½ (140)	11 (279)	3 (76)	4½ (114)	6 (152)	20¼ (514)
4" (100 mm)	8½ (215)	8 (203)	10½ (267)	14 (356)	24 (610)	24¼ (616)	16 (406)	25 (635)	38¼ (972)	30 (762)	7½ (191)	11¾ (298)	5½ (140)	8¼ (210)	13½ (343)	5 (127)	6¾ (171)	4¼ (108)	21¾ (552)
6" (150 mm) & 165 mm	8½ (215)	9 (229)	11½ (292)	16 (406)	26¾ (679)	27½ (699)	19 (483)	27½ (699)	40¾ (1035)	32½ (826)	8 (203)	12 (305)	5½ (140)	8¼ (210)	13¾ (349)	4¾ (121)	6½ (165)	4¼ (108)	22¼ (565)
8" (200 mm)	8½ (215)	9¼ (248)	12¼ (311)	19¾ (492)	30¾ (781)	30¼ (768)	N/A	27¾ (705)	41 (1041)	32¾ (832)	9 (229)	12¾ (324)	5½ (140)	8¼ (210)	14½ (368)	3½ (89)	5¼ (133)	4¼ (108)	23¼ (591)

D* is total takeout for Fully Assembled to Grv/Grv DDX Valve w/o Control Valve Configurations

D** is total takeout for Fully Assembled to Grv/Grv DDX Valve w/ Control Valve Configurations

D*** is total takeout for Fully Assembled to Flg/Grv DDX Valve wo/ Control Valve Configurations

D**** is total takeout for Fully Assembled to Flg/Flg DDX Valve wo/ Control Valve Configurations

TRIM SHOWN FULLY ASSEMBLED WITHOUT CONTROL VALVE

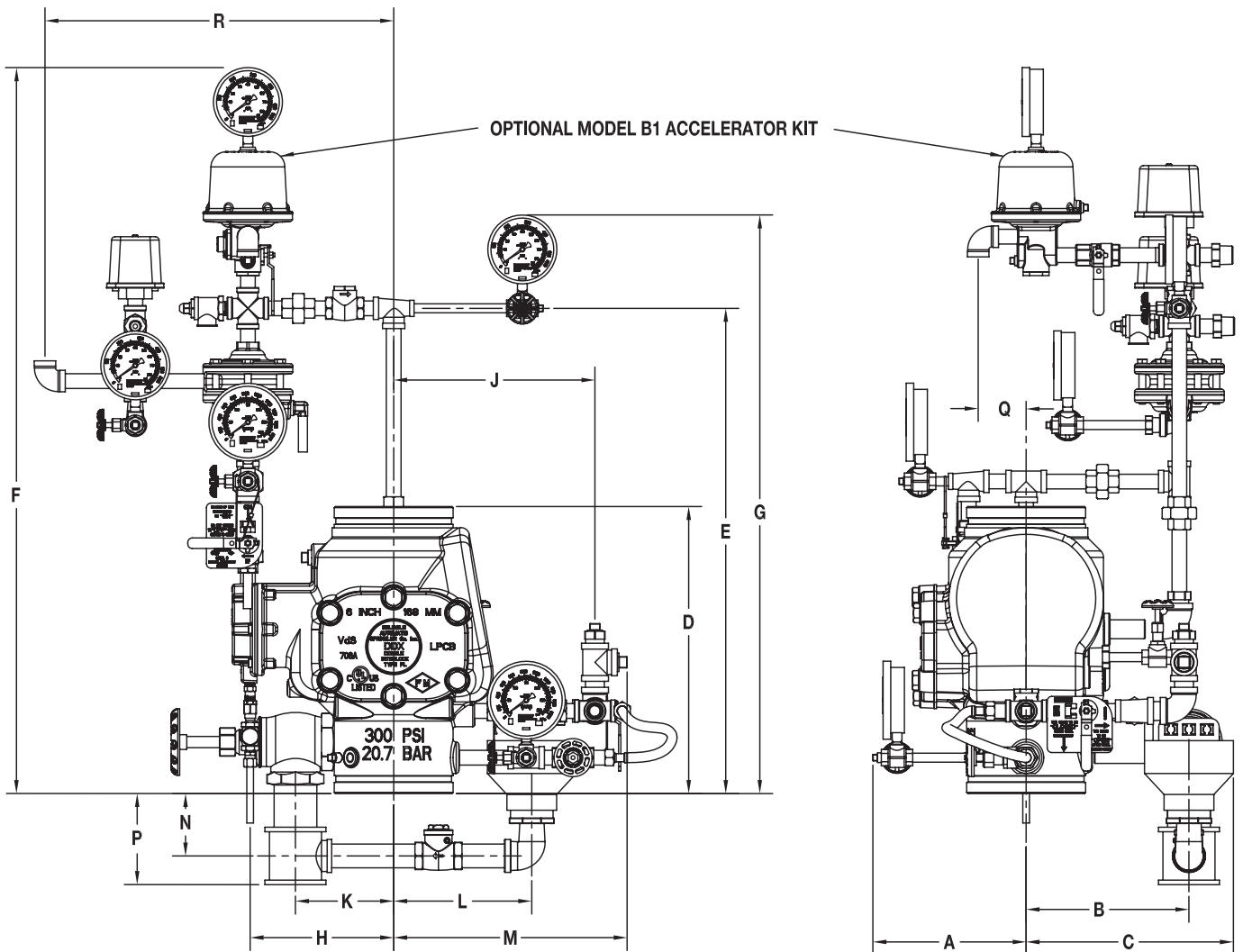

752BKP8

Reliable . . . For Complete Protection

Reliable offers a wide selection of sprinkler components. Following are some of the many precision-made Reliable products that guard life and property from fire around the clock.

- Automatic Sprinklers
- Flush Automatic Sprinklers
- Recessed Automatic Sprinklers
- Concealed Automatic Sprinklers
- Adjustable Automatic Sprinklers
- Dry Automatic Sprinklers
- Intermediate Level Sprinklers
- Open Sprinklers
- Spray Nozzles
- Alarm Valves
- Retarding Chambers
- Dry Pipe Valves
- Accelerators for Dry Pipe Valves
- Mechanical Sprinkler Alarms
- Electrical Sprinkler Alarm Switches
- Water Flow Detectors
- Deluge Valves
- Detector Check Valves
- Check Valves
- Electrical System
- Sprinkler Emergency Cabinets
- Sprinkler Wrenches
- Sprinkler Escutcheons and Guards
- Inspectors Test Connections
- Sight Drains
- Ball Drips and Drum Drips
- Control Valve Seals
- Air Maintenance Devices
- Air Compressors
- Pressure Gauges
- Identification Signs
- Fire Department Connections

The equipment presented in this bulletin is to be installed in accordance with the latest published Standards of the National Fire Protection Association, Factory Mutual Research Corporation, or other similar organizations and also with the provisions of governmental codes or ordinances whenever applicable.

Products manufactured and distributed by Reliable have been protecting life and property for almost 100 years.

Manufactured by

Reliable[®]

Reliable Automatic Sprinkler Co., Inc.

(800) 431-1588

(800) 848-6051

(914) 829-2042

www.reliablesprinkler.com

Sales Offices

Sales Fax

Corporate Offices

Internet Address



Recycled
Paper

Revision lines indicate updated or new data.

EG. Printed in U.S.A. 10/16 P/N 999970444